

中速机边粉碎机RG-16R/21R
Middle-speed granulator



低速机边粉碎机RG-18/20/23
Low-speed granulator



慢速机边粉碎机RG-27R
Slow-speed granulator

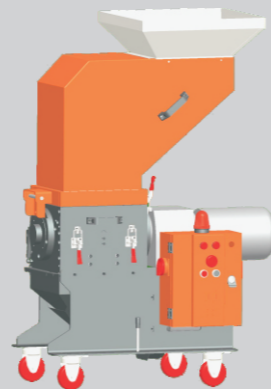

机边立即回收粉碎机,此机安装在机台旁,配以机械手,将小型水口料立即粉碎并按一定比例与新料混合使用;既减少原料的浪费,又减轻了原料的污染源;大大提高了原料的利用率,同时也节省了人力资源,降低了企业成本。

Description :
RG Series beside-the-press granulators are installed beside injection molding machine, feeding by robot or manpower, to crush small stub bar. The machine works to reduce the material waste and pollution, and increase the material availability to save manpower and production cost.

两料比例阀功能是将新料与粉碎料按照一定比例混合后送到干燥机内使用,比例阀需配合上料机一起使用。
RPV Proportional Valve work together with hopper dryer and auto loader, used for conveying regrind and raw material which mix proportionally to inside of hopper dryer.

两料比例阀RPV
Ratio valve of two materials

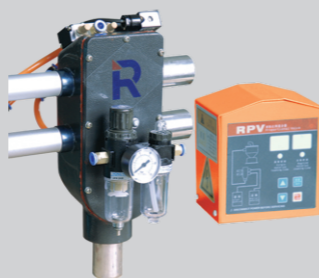

Wechat



Webiste

更多咨询请访问:
www.rhongmachinery.com (EN)

宁波北仑日宏机械制造有限公司
Ningbo Beilun Rhong Machinery Manufacturing Co.,Ltd

地址:浙江.宁波.北仑.小港街道.东岗碶.
Donggangqi, Xiaogang Subdistrict, Beilun,
Ningbo, Zhejiang Province, China.
T +86-574-55019010, MB:0086 137 7723 9417
F +86-574-55019017
E-mail: rhong@plastic-auxiliary-equipment.com(EN)

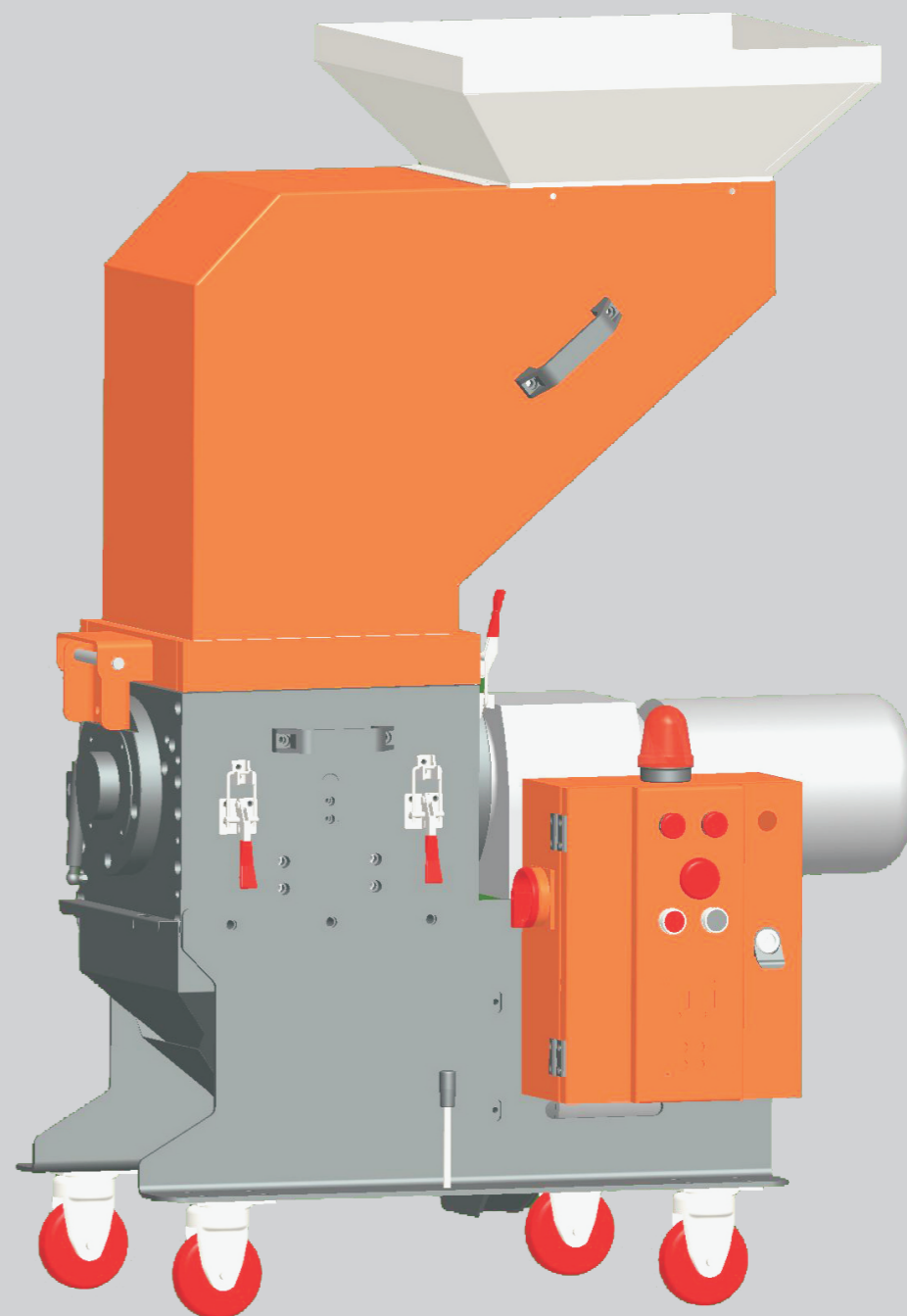

中速机边粉碎机RG-16R/21R
Middle-speed granulator
低速机边粉碎机RG-18/20/23
Low-speed granulator
慢速机边粉碎机RG-27R
Slow-speed granulator

标配立即回收器，与注塑机连接，将粉碎料与废料按一定比例立即回收使用。
Equipped with instant recycle device, connecting with the injection molding machine, regrind material and raw material according to a certain percentage of immediate recovery.

错刀式(齿啃式)结构，分散冲击负荷，切削效率高，免调刀的刀架设计，刀具更换简便。
刀具采用高铬钢材料，强度高，坚固耐用。
toothed rollers blades design, scatter impact load, high cutting efficiency, no need to adjust the cutter frame design, easy to change blades
The hardened cutting tools made from high chrome steel alloys guarantee a long service life even when processing abrasive plastics

电机设过载保护，保护电机安全。
Overload device to protect motor.

品牌减速机直接传动，传动效率高(0.97-0.995)，粉碎能力更强，更节省能源。
小功率，低噪音，特别适合于无尘静音车间。
Direct transmission reducer motor with high efficiency (0.97-0.995), works with high capacity and energy-saving Lower power and lower noise, suitable for quiet and dust-free workshop.

配置了万向脚轮，方便放置在合适的位置。
Equipped with universal casters, conveniently placed in the right place.

气弹簧设计，防止上下粉碎室在闭合过程中突然碰撞，保证了操作人员的安全。
Air spring design, prevent the upper and lower cutting chamber from sudden collision during closure, to make sure workers safety.

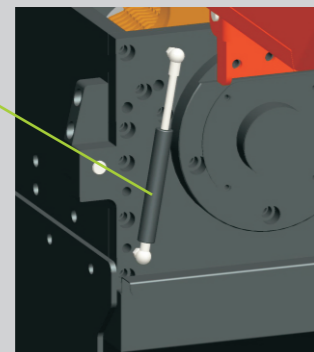

上下粉碎室设计，方便清扫。
Upper and lower cutting chamber design, easy to clean.
将手柄插入此孔位，转动手柄，可清洁刀槽内废料。
Insert the handle into this hole and turn the handle to clean the waste material in the blade slot.

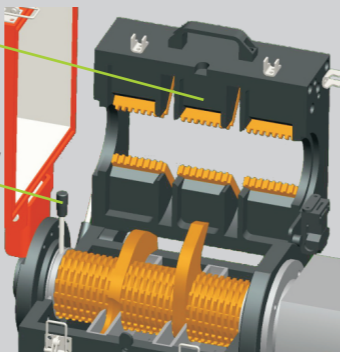

进料斗内层，进料嘴均采用不锈钢制作，减少原料的污染。
Inner layer of feeding hopper and feeding mouth are made of stainless steel, reduce the material pollution.

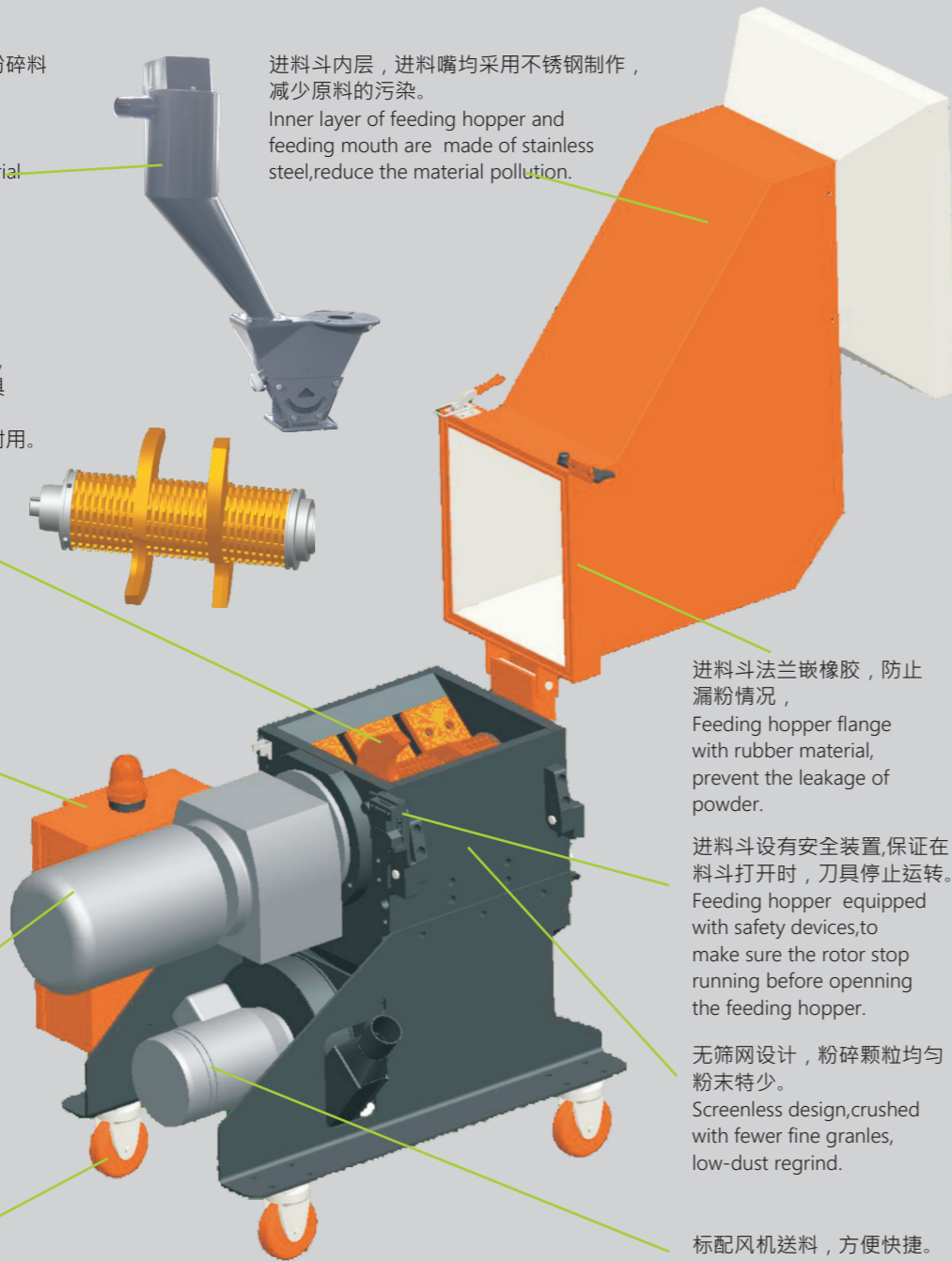

进料斗法兰嵌橡胶，防止漏粉情况，
Feeding hopper flange with rubber material, prevent the leakage of powder.

进料斗设有安全装置，保证在料斗打开时，刀具停止运转。
Feeding hopper equipped with safety devices, to make sure the rotor stop running before opening the feeding hopper.

无筛网设计，粉碎颗粒均匀，粉末特少。
Screenless design, crushed with fewer fine granules, low-dust regrind.

标配风机送料，方便快捷。
Equipped with blower feeding system, convenient and quick.

Beside-the-press granulator installation diagram
----Proportional valve feeding system

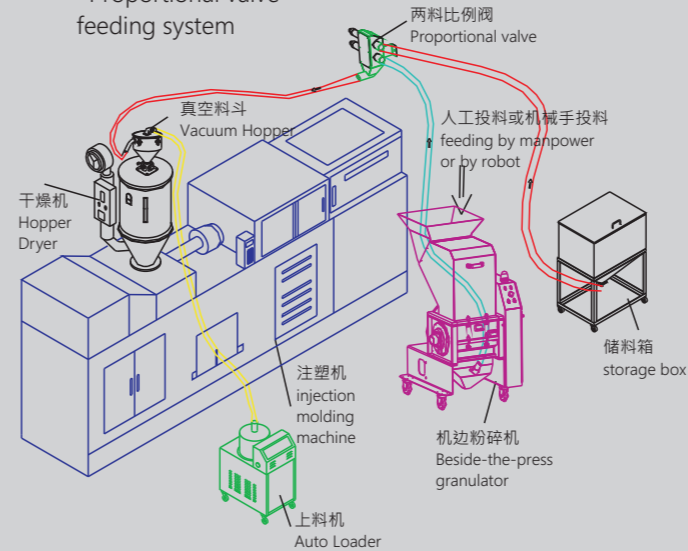

机边机安装示意图
两料比例阀送料型

Beside-the-press granulator installation diagram
----Blower system

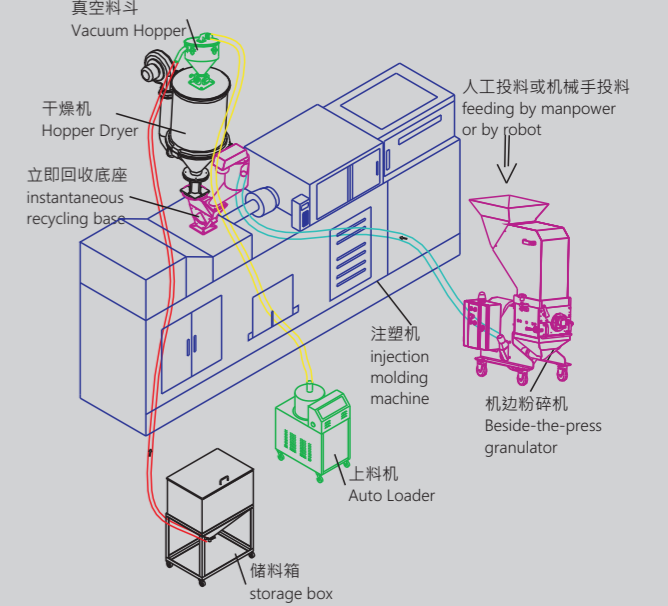

机边机安装示意图
---风机送料型

规格表 Specifications

机型 Model		RG-2720R	RG-2730R	RG-2740R	RG-2750R
电机功率 Power	kw	0.75	1.5	2.2	2.2
主轴转速 Rotor speed	rpm	38	38	38	38
爪刀 Staggered blades	PCS	1	2	3	4
齿刀 Teeth blades	PCS	2	3	4	5
固定刀 Fixed blades	PCS	5	7	9	11
粉碎室尺寸 Cutting chamber size	mm	275X200	275X300	275X415	275X525
粉碎能力 Output	kg/h	8~10	10~15	15~25	25~40
粉碎时噪音 Noise	dB(A)	60~75	60~75	60~75	60~75
风机送料系统 Blower conveying system		●	●	●	●
立即回收系统 Instant recycling system		●	●	●	●
比例阀送料装置 Proportional-valve conveying device		○	○	○	○
人工接料箱 Material box		○	○	○	○
重量 Weight	kg	280	350	400	450
外形尺寸(L×W×H) External size	mm	860X615X1395	970X615X1395	1120X615X1495	1230X615X1495

产品规格若有变更，恕不另行通知。
Please excuse for not note if some specifications of products are changed.

Note 注：

- "为标配，○"为选购。
● "is standard allocation, ○"is selection purchase.
- 最大粉碎量取决于粉碎材料等因素。
The max. shredding quantity depend on the shredding material quality.
- 为避免塑料粘刀，粉碎前，所有待粉碎料的温度应保证在常温状态温度。
In order to avoid the waste material with high temperature stuck into blades surface, all waste material should be at normal temperature before crushing
- 机器电压规格为3Φ,380V,50Hz。
The machine voltage specification is 3Φ,380V,50Hz.
The voltage can be changed as you require.

