

# SANCO ELECTRONICS CO., LTD.

## A. SCOPE

This specification applies Piezo buzzer, **SPT-1460A-09040J**

## B. SPECIFICATION

No.	Item	Unit	Specification	Condition
1	Oscillation Frequency	Hz	4000	Square Wave
2	Operating Voltage	Vp-p	1~15	
3	Rated Voltage	Vp-p	9	
4	Current Consumption	mA	MAX. 3	at Rated Voltage
5	Sound Pressure Level	dB	MIN. 88	at 10cm at Rated Voltage
6	Electrostatic Capacity	pF	15000±30%	at 100Hz 1V
7	Operating Temperature	°C	-20~ +85	
8	Storage Temperature	°C	-30 ~ +85	
9	Dimension	mm	Φ14x H6.0	See appearance drawing
10	Weight (MAX)	gram	1.0	
11	Housing Material		LCP( PPS )	
12	Leading Pin		Plated Brass(Au)	See appearance drawing
13	Environmental Protection Regulation		RoHS	

## C. APPEARANCE DRAWING

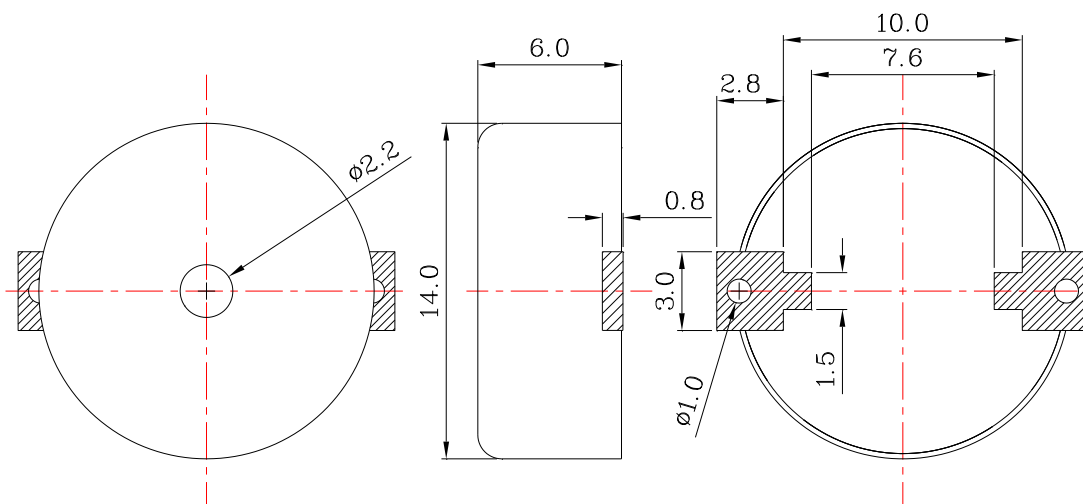

**Tol : ± 0.5**

**Unit: mm**

SANCO ELECTRONICS CO., LTD.  
TEL: +86-574-83851068 FAX: +86-574-83851096  
EMAIL: [Sales@sancoelectronics.com](mailto:Sales@sancoelectronics.com)

## D. TESTING METHOD

### Standard Measurement conditions

Temperature:  $25 \pm 2^\circ\text{C}$  Humidity: 45-65%

### Acoustic Characteristics:

The oscillation frequency, current consumption and sound pressure are measured by the measuring instruments shown below

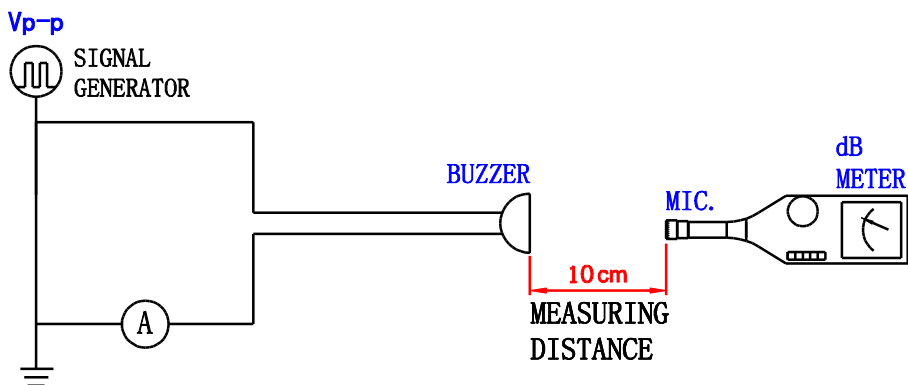

In the measuring test, buzzer is placed as follows:

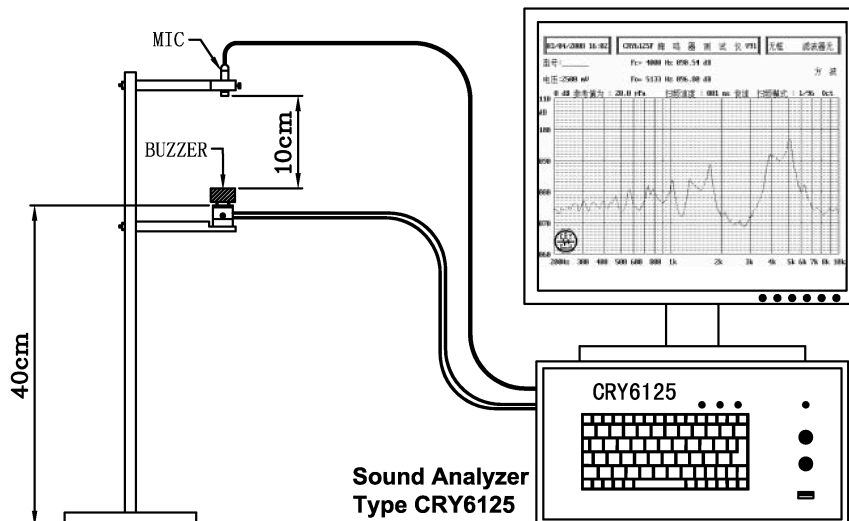

## E. Typical Frequency Response Curve

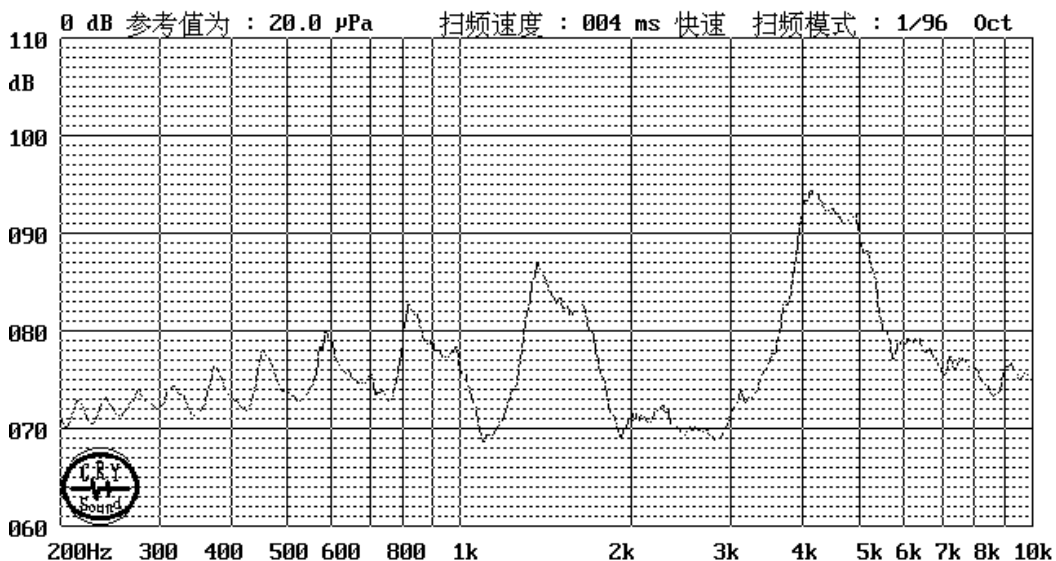

## F. Soldering Condition

(1) Recommendable reflow soldering condition is as follows

(Reflow soldering is twice)

Note: It is requested that reflow soldering should be executed after heat of product goes down to normal.

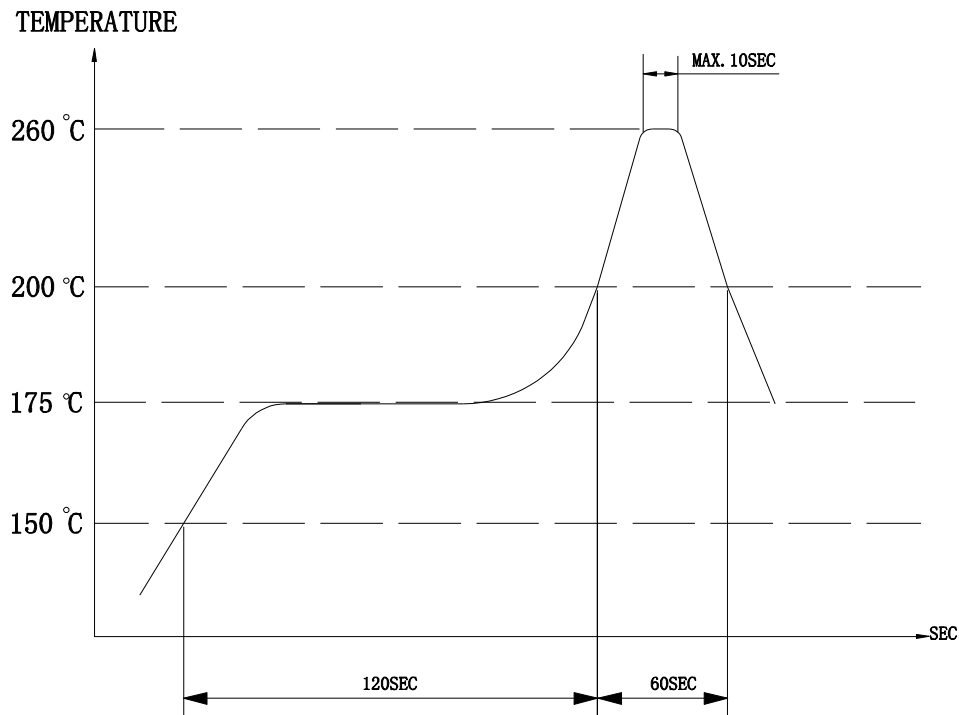

Heat resistant line

(Used when heat resistant reliability test is performed)

(2) Manual soldering

Manual soldering temperature 350 °C within 5 sec.

## G. RELIABILITY TEST

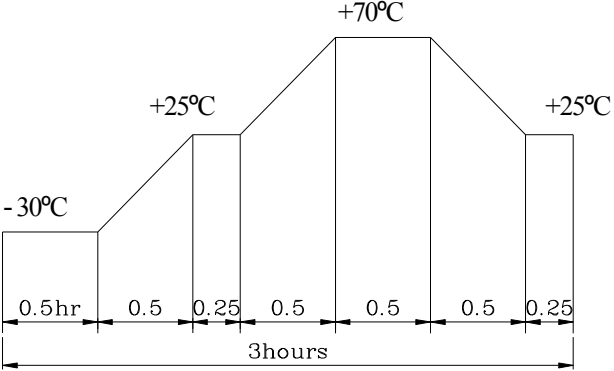
NO.	ITEM	TEST CONDITION AND REQUIREMENT
1	High Temperature Test (Storage)	After being placed in a chamber with 85±2°C for 96 hours and then being placed in normal condition for 2 hours. Allowable variation of SPL after test: ±10dB.
2	Low Temperature Test (Storage)	After being Placed in a chamber with -40±2°C for 96 hours and then being placed in normal condition for 2 hours. Allowable variation of SPL after test: ±10dB.
3	Humidity Test	After being Placed in a chamber with 90-95% R.H. at 40±2°C for 96 hours and then being placed in normal condition for 2 hours. Allowable variation of SPL after test: ±10dB.
4	Temperature Cycle Test	<p>The part shall be subjected to 5 cycles. One cycle shall be consist of :</p>  <p style="text-align: center;"> <span style="margin-right: 100px;">-30°C</span> <span style="margin-right: 100px;">+25°C</span> <span style="margin-right: 100px;">+70°C</span> <span style="margin-right: 100px;">+25°C</span> </p> <p style="text-align: center;"> <span style="margin-right: 100px;">0.5hr</span> <span style="margin-right: 100px;">0.5</span> <span style="margin-right: 100px;">0.25</span> <span style="margin-right: 100px;">0.5</span> <span style="margin-right: 100px;">0.5</span> <span style="margin-right: 100px;">0.5</span> <span style="margin-right: 100px;">0.25</span> </p> <p style="text-align: center;">3hours</p> <p>Allowable variation of SPL after test: ±10dB.</p>
5	Drop Test	Drop on a hard wood board of 4cm thick, any directions ,6 times, at the height of 75cm . Allowable variation of SPL after test: ±10dB.
6	Vibration Test	After being applied vibration of amplitude of 1.5mm with 10 to 55 Hz band of vibration frequency to each of 3 perpendicular directions for 2 hours . Allowable variation of SPL after test: ±10dB.
7	Solderability Test	Lead terminals are immersed in rosin for 5 seconds and then immersed in solder bath of +300±5°C for 3±1 seconds . 90% min. lead terminals shall be wet with solder (Except the edge of terminals).
8	Terminal Strength Pulling Test	The force of 9.8N(1.0kg) is applied to each terminal in axial direction for 10 seconds. No visible damage and cutting off.

### TEST CONDITION.

Standard Test Condition	:	a) Temperature : +5 ~ +35°C	b) Humidity : 45-85%	c) Pressure : 860-1060mbar
一般测试条件	:	a) 温度 : +5 ~ +35°C	b) 湿度 : 45-85%	c) 气压 : 860-1060mbar
Judgment Test Condition	:	a) Temperature : +25 ± 2°C	b) Humidity : 60-70%	c) Pressure : 860-1060mbar
争议时测试条件	:	a) 温度 : +25 ± 2°C	b) 湿度 : 60-70%	c) 气压 : 860-1060mbar

## H. PACKING STANDARD

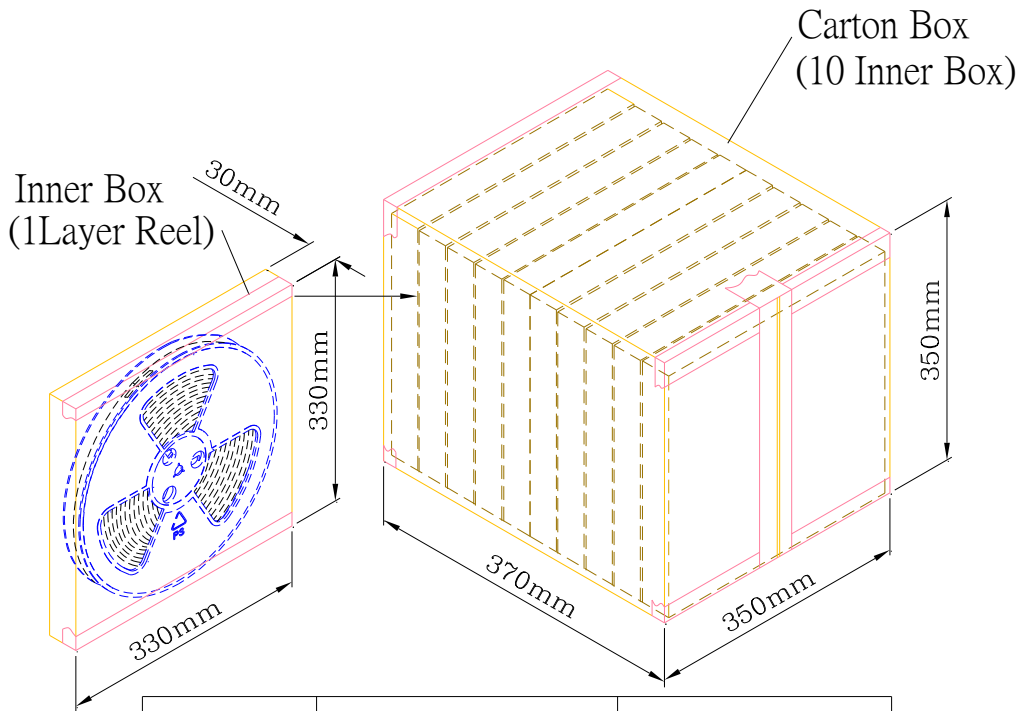
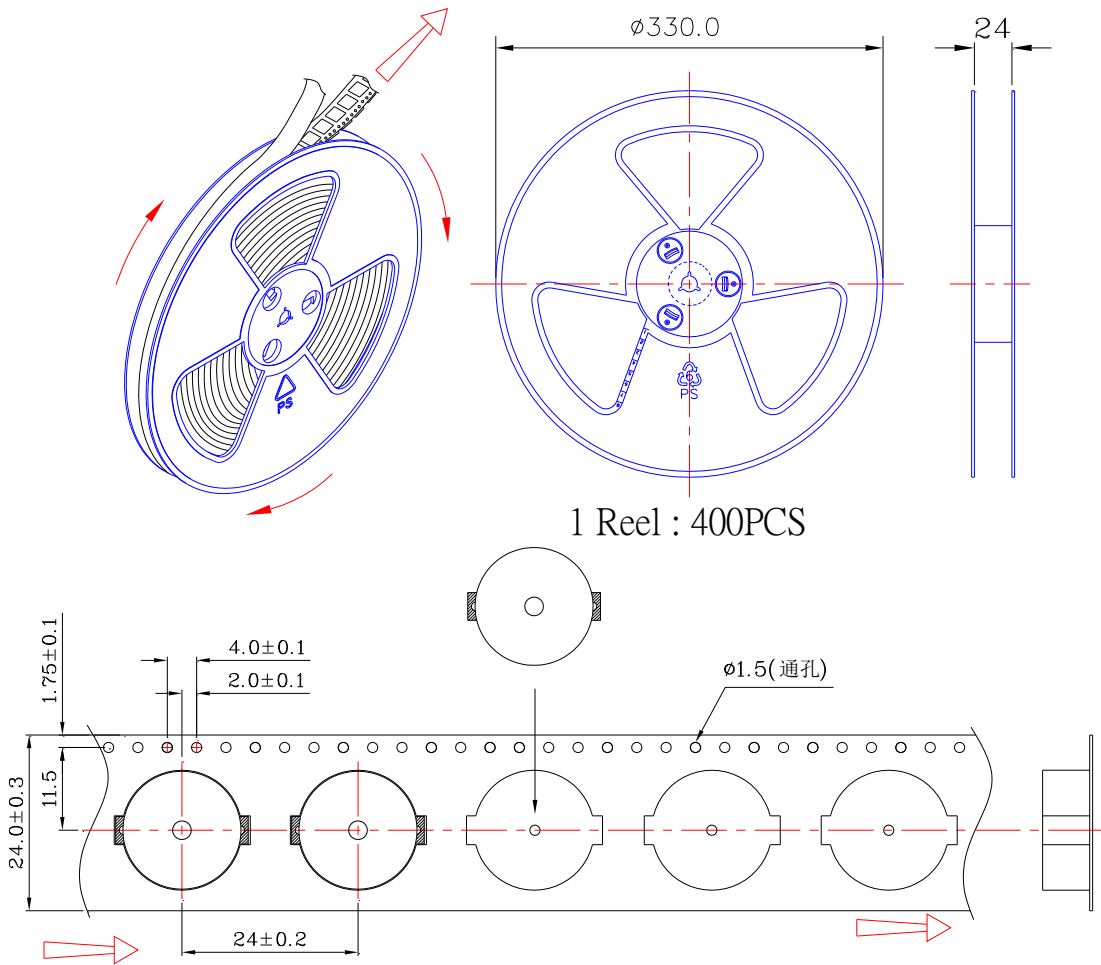

Inner Box	330mmx330mmx30mm	1x400PCS=400PCS
Carton Box	350mmx350mmx370mm	10x400PCS=4,000PCS