

DM-33RS385 DC SPUR GEAR MOTOR

基本电压/Main Voltage : 12VDC、24VDC

典型应用/Typical Applications :

仪器仪表、电动工具、咖啡机、自动贩卖机、按摩器、游戏机、电动开窗器、自动化设备等。

Instrument, Electric tools, Coffee machine, Vending machine, Massager, Game machine, Electric window opener, Automation equipment

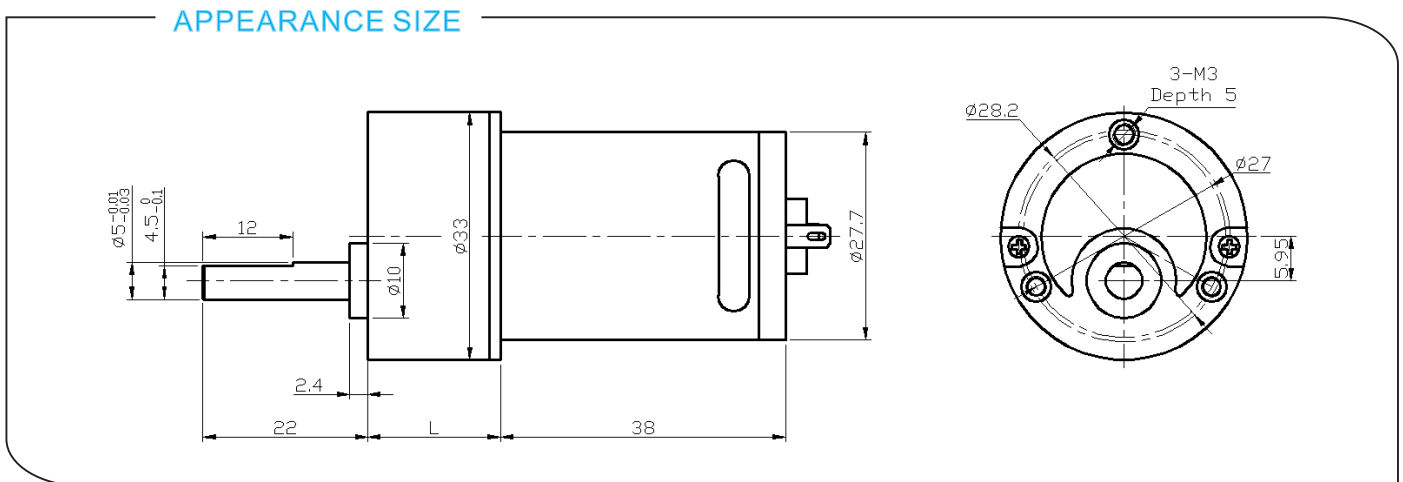

减速箱参数/Gearbox Data:

级数 Number of stages	3	4	5	6	7
减速比 Reduction ratio	20	50	125	312.5	781
减速箱长度 Gearbox length "L" mm	17.7	19.9	22.2	24.4	26.75
破坏扭矩 Breaking torque(kgf.cm)	10	15	20	24	24
减速箱效率 Gearbox efficiency	73%	65%	59%	53%	48%

电机参数/Driving Motor Data:

电机型号 Motor model	额定电压 Rated Volt.	空载/No load		负载/Load				堵转/Stall	
		电流 Current	转速 Speed	电流 Current	转速 Speed	扭矩 Torque	输出功率 Output power	扭矩 Torque	电流 Current
		V	mA	r/min	mA	r/min	g.cm	W	g.cm
DM-385-012-3000	12	≤60	3000	≤150	2200	35	0.8	≥110	≥360
DM-385-012-4500	12	≤70	4500	≤300	3300	55	1.9	≥210	≥960
DM-385-012-6000	12	≤100	6000	≤600	4500	80	3.7	≥280	≥1600
DM-385-024-3000	24	≤28	3000	≤70	2200	35	0.8	≥110	≥160
DM-385-024-4500	24	≤50	4500	≤150	3300	55	1.9	≥180	≥380
DM-385-024-6000	24	≤70	6000	≤300	4500	80	3.7	≥250	≥800

备注/Remark:

齿轮减速箱额定扭矩 = 电机额定扭矩 * 减速比 * 减速箱效率

Gear Motor Torque = Driving motor torque * Reduction ratio * Gearbox efficiency;

齿轮减速箱额定转速 = 电机额定转速 / 减速比

Gear Motor Speed = Driving motor speed / Reduction ratio

电机具体配置可根据客户的要求进行定制, 像电压, 速度, 以及轴的长度和形状...

Motor detailed config can be customized according to customer's requests, like voltage, speed, as well as shaft length and shape...

欢迎OEM或ODM项目

Welcome OEM or ODM projects