

HSF

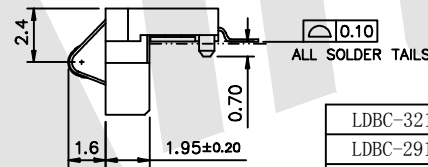

ROHS

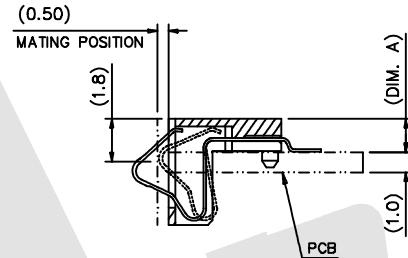
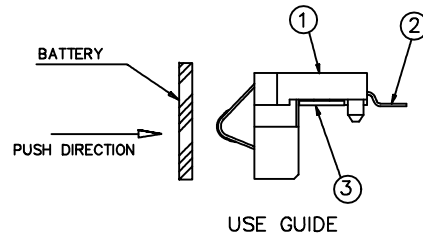
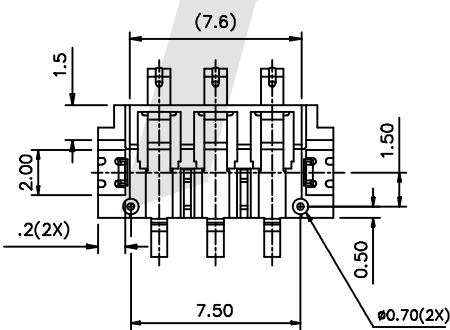
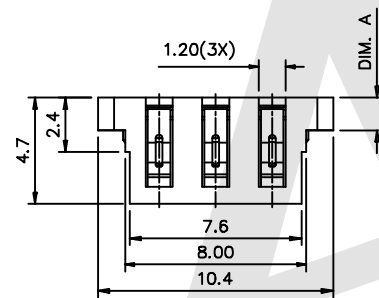
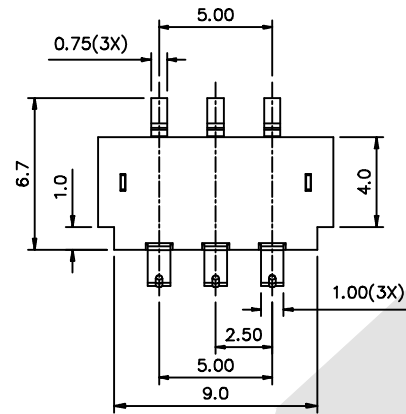

LDBC-3215-2	1.50
LDBC-2918-2	1.80
P/N	DIM. A

TABLE I

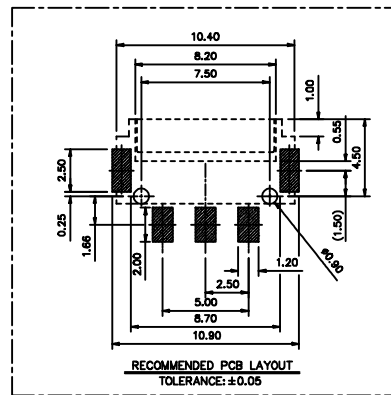

NOTES

- MATERIAL:
 - PIN:BERYLLIUM COPPER
 - INSULATOR: 30% GLASS-FILLED THERMOPLASTIC LCP OR EQUIVALENT
UL94V-0, BLACK.
- FINISH: CONTACT:GOLD FLASH(1" MIN.) ALL OVER, 50-100 MICROINCH (1.27-2.54 MICRON) NICKEL UNDERPLATED ALL OVER
SOLDER TAB:50-100(1.27-2.54 MICRON) MICROINCH MATTE TIN,
10-100 MICROINCH(1.27-2.54 MICRON) NICK UNDERPLATED
- ELECTRICAL SPECIFICATIONS:
 - VOLTAGE RATING:250 VAC MIN
 - CURRENT RATING:2.0 A MIN
 - DIELECTRIC STRENGTH:1000 VAC FOR 1 MINUTE MIN
 - INSULATION RESISTANCE:1000 MEG OHM MIN
 - CONTACT RESISTANCE:30 MILL. OHM MAX
 - OPERATION TEMPERATURE:-55° C TO +125° C
 - PRODUCT WITHSTANDING REFLOW SOLDERING 260° FOR 10S
- MECHANICAL SPECIFICATIONS:
 - DURABILTY:5.000 CYCLES
 - NOTMAL FORCE AT MATED POSITION:60g MIN
 - NOTMAL FORCE AT FULL STROKE:100g MIN
- PARTS TO BT PACKAGED IN ANTI-STATIC TAPE AND REEL FOR AUTOMATIC PLACEMENT.
- THE CAVITY# IS 0.8±0.10mm HIGH WITH 0.10±0.10mm RECESSED FROM SURFACE.

Ordering Code:

ABT10 - 03 - L - B - X - D
① ② ③ ④ ⑤ ⑥

- | | |
|-----------------------|--------------------|
| ① Series No: | ⑤ Contact Plating: |
| ② No. of Contacts | G0:Gold flash |
| 03:03Pin | G1:3u" gold |
| ③ Insulator Material: | G2:5u" gold |
| P:PBT+30%GF | G3:10u" gold |
| L:LCP | G4:15u" gold |
| ④ Pitch | G5:30u" gold |
| B:2.5mm | ⑥ Packing: |
| Pitch | A:Tray |
| | B:Bag |
| | C:Tube |
| | D:Tape Reel |

Unless Otherwise specified tolerance
X. ±0.35 X.XX: ±0.20
X.X: ±0.25 X.XXX: ±0.15

Antenk ANTENK ELECTRONICS CO., LTD
Http://www.antenk.com
E-mail:sales@antenk.com

SCALE: As Shown	UNIT: mm
DRAW Wu Feng Rong	DATE 22/03/2018
CHECK BobYang	DATE 22/03/2018

TITLE:
2.5mm Pitch 3P Battery Connector
(In Board Type C)



DRAWING NO: ABT10-03LBXD

PRODUCT NO: ABT10-03LBXD

REV	DESCRIPTION	DATE

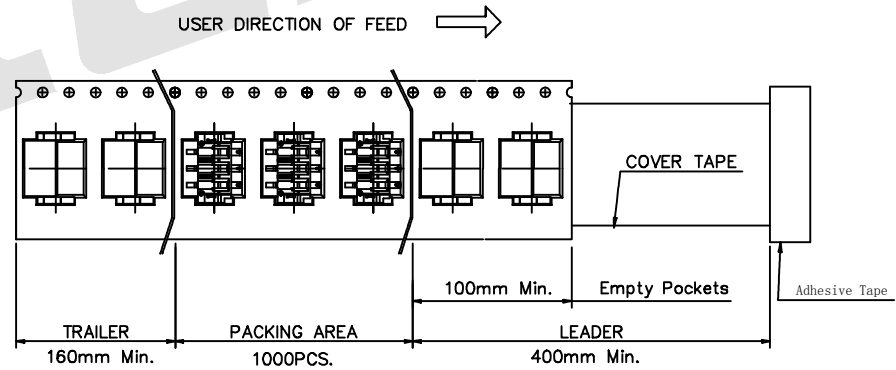
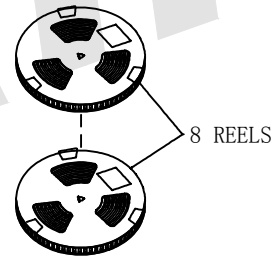
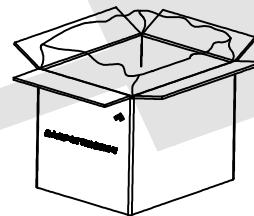
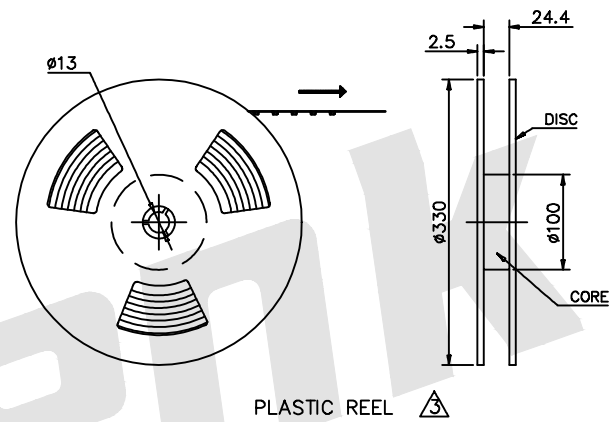
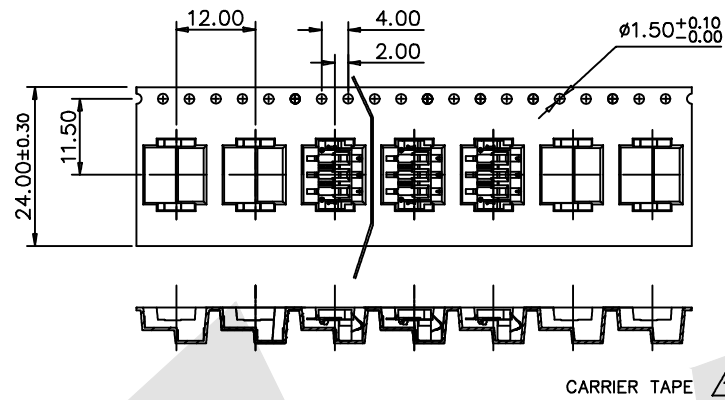

NOTES:

- ① CARRIER TAPE MATERIAL: THERMOPLASTIC ANTI-STATIC FILM OR EQUIVALENT THICKNESS: 0.40±0.05mm, COLOR: BLACK OR TRANSPARENT.
- ② COVER TAPE MATERIAL: CONDUCTIVE COVER TAPE OR EQUIVALENT.
- ③ PLASTIC REEL MATERIAL: PS, COLOR: BLUE.
- 4. PEEL STRENGTH REQUIREMENT OF COVER TAPE TO COMPLY WITH EIA-481.
- 5. ALL TAPE AND SPROCKET HOLE DIMENSIONS SHOWN ARE PER EIA-481.
- 6. PACKING QUANTITY: 1000 PCS PER REEL 8000 PCS PER BOX..

Unless Otherwise specified tolerance	
X. ±0.35	X.XX: ±0.20
X.X: ±0.25	X.XXX: ±0.15

Antenk® ANTENK ELECTRONICS CO., LTD
[Http://www.antenk.com](http://www.antenk.com)
 E-mail:sales@antenk.com

SCALE: As Shown	UNIT: mm
DRAW Wu Sai	DATE 22/03/2018
CHECK BobYang	DATE 22/03/2018

TITLE:
2.5mm Pitch 3P Battery Connector
(In Board Type C)

DRAWING NO: ABT10-03LBXD

PRODUCT NO: ABT10-03LBXD

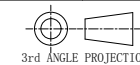

REV	DESCRIPTION	DATE