

2.5W 250LM 15°*45° IP68 LifeSpan 50,000h

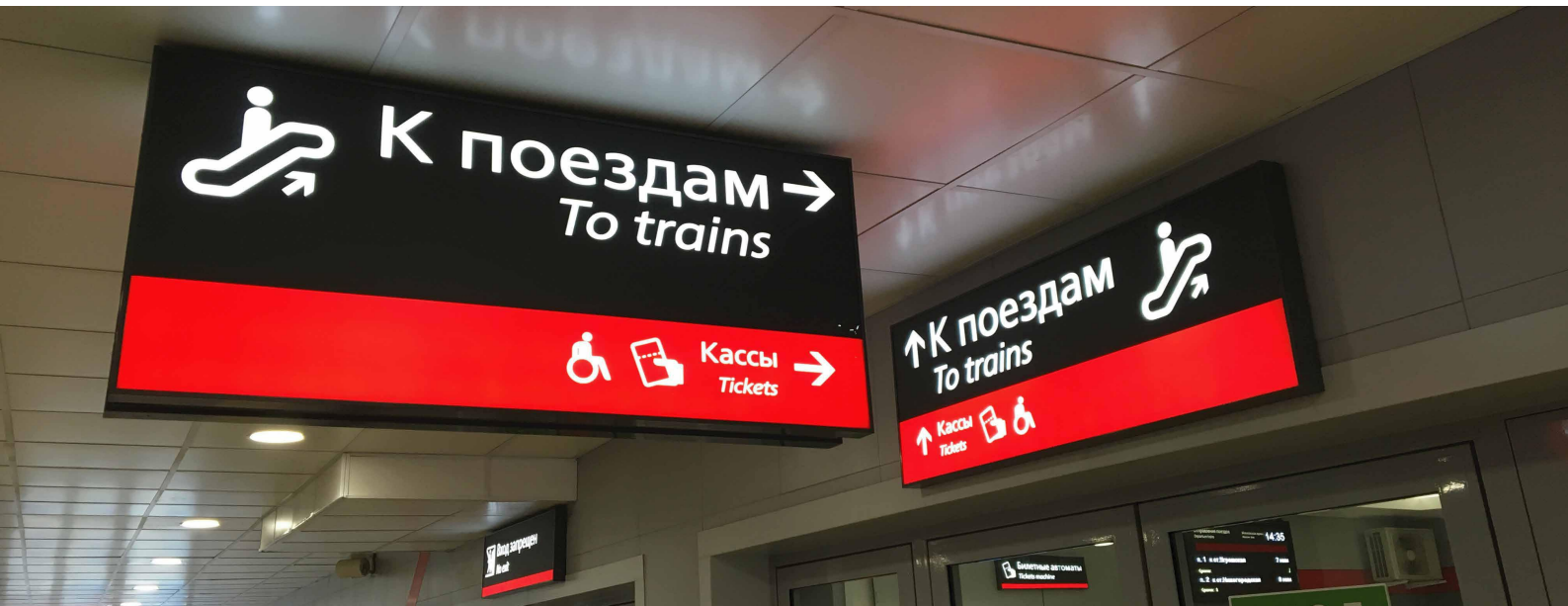
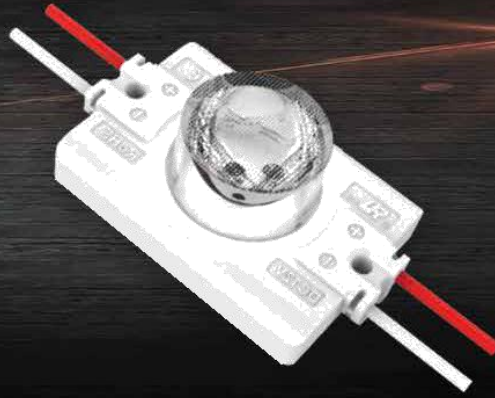

Features

- Sourced by high output SMD3535, good color conformity and no spot.
- 99.99% gold thread, pure copper bracket coated with silver.
- SDCM≤5 each BIN.
- Special lens design, 15°*45° beaming angle with even light.
- Overmoulded: anti-dusting, anti-moisture, waterproof, anti-shock.
- 10 pcs Max. in a series connection.
- CE, ROHS and UL certified.

Application

- Best for 15-30cm depth double-sided light box or 8-20 cm depth single-sided light box at airports, metros, banks, buildings and shopping malls, etc.

Parameters >

Items	Parameters
Part Number	ZX01BB2
CCT (K)	7000K
Beaming Angle (°)	45*15
CRI (Ra)	≥75
Luminous Flux (lm)	250
Voltage (V)	DC12
Power (W)	2.5
Driving Method	Inner Constant Current
Dimension (mm)	51.4*32*14.8
Weight (g)	20
Working Tem. (°C)	-25 ~ +60
Storage Tem. (°C)	-25 ~ +70
Protection Grade	IP67

Dimension >

Unit:mm

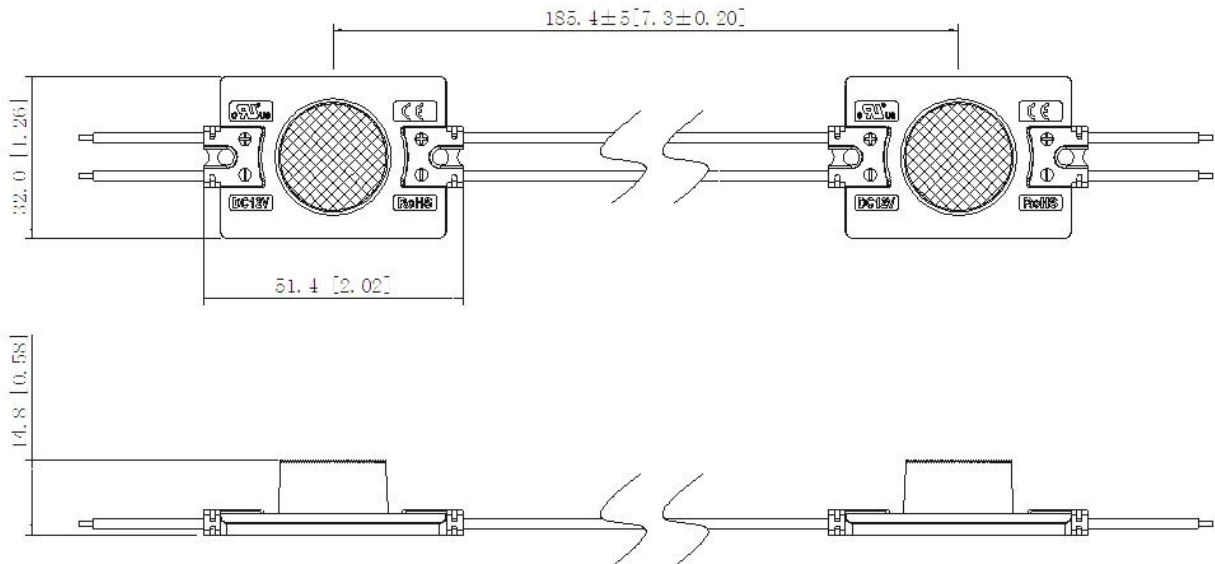

Beaming Angle >

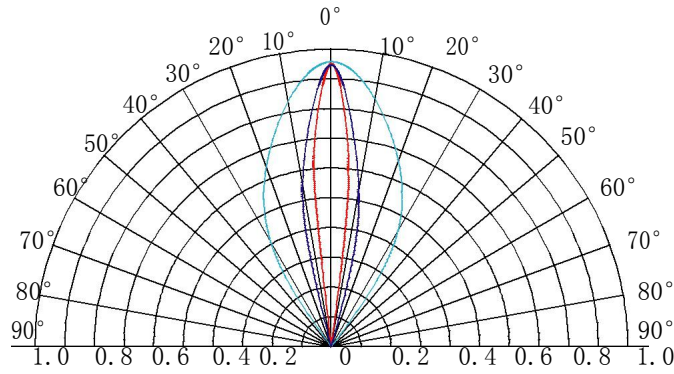

Reference Scheme >

Depth(mm)	Size(mm)	Density(pcs/m ²)	Illumination(lux)
180	1000*1000	24	800-900
200	1000*1000	24	700-800
300	1000*1000	24	600-650

Remark:

- The transmittance of the advertising fabric was 32%.
- The above data is for reference only.

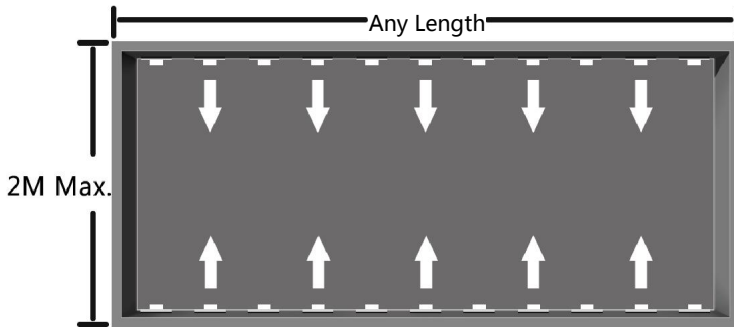

Wire Connection >

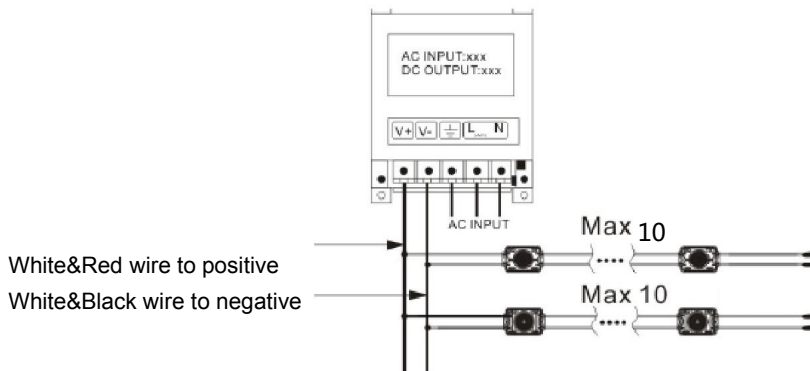

Packing

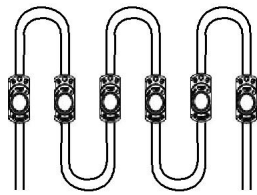

10pcs per string

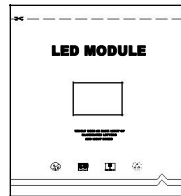

60pcs per antistatic bag

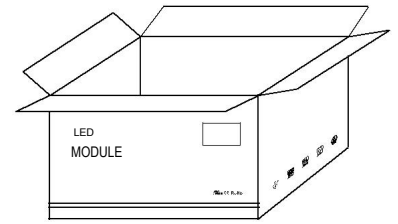

600 pcs per carton

Packing Specification

- Antistatic bag adopted
- Packing information

Part Number	ZX01BB2
Carton Dimension(mm)	490*450*220
Bags per carton	10
Quantity per carton(pcs)	600
Net Weight(kg)	12.5(1±10%)
Gross Weight(kg)	13.8(1±10%)

- Due to the packing manner difference, please subject to the original products in case of discrepancy found between the picture and actual product.

Instruction

- When installing the product, please switch off the power
- Please use constant voltage power supply and leave 20% or more balance of its total
- power Make isolation and corrosion prevention on all wiring points and wire ends
- The maximum series connection quantity for ZX01BB2 is 10 pcs , please do not exceed this number
- The products can be installed by screws, rivets as well as silicon gel, while please do not use Acidic or alkaline adhesive
- The high power LEDs generates more heat, so please install the products on the surface of material with good heat dissipation such as metallic or aluminium panel
- For single side light box, in order to get better and even lighting effect, you can put the products more closer to unilluminated back and attach white reflective poly sheet or sheet with similar function on the inner back.

- The high power LED generates more heat, please install the products on the surface of material with good heat dissipation like aluminium panel.
- When choosing power supply, please leave 20% or more balance of its total power.

Declaration >

- Warranty: 5 years.
- In order to ensure the safety, the broken wires needs to be replaced by the manufacturer or the service agent, or by the staff with the similar qualification.
- The given data in the specification was based on the laboratory testing, there may be discrepancy found in the actual products.
- The given drawings in the specification are only for reference, there may be discrepancy found in the actual products.
- The products are subject to change without prior notification.



RoHS

Company Address:

Rm. WS, 9F, LuBan Building, Hongli West Road, Futian District, Shenzhen, China 518034

Factory Address:

No. B, Xinyongfeng Industrial Area, Yingrenshi Village, Shiyuan Town, Bao'an District, Shenzhen, China 518000

TEL: +86-755-83544570

FAX: +86-755-83056229

Website: www.lbyled.com

E-mail: info@szlby.cn



LBY LED
signs never been so easy