

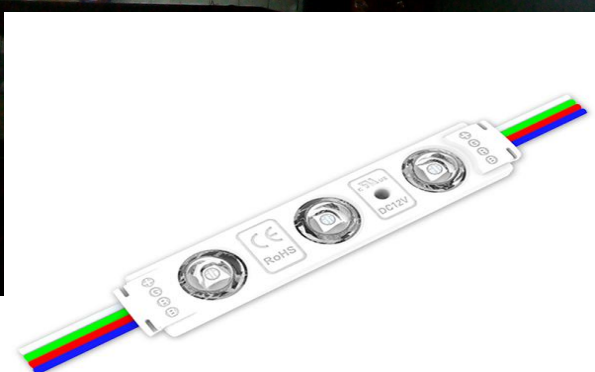

LBY LED

# WAL★MART *SUPERCENTER* 沃尔玛购物广场



ZH03QA5-Q RGB module

SMD 5050 LED



RoHS



Shenzhen LingBenYang Co.,Ltd.

Rm.WS , 9F, LuBan Building, Hongli West Road, Futian District, Shenzhen, China

Tel:+86-755-8354-4570

Fax:+86-755-8305-6229

Web:www.szlby.cn

Email:info@szlby.cn



## Application

Apply to 8-18 cm depth signs at airports, metros, banks, buildings and shopping malls, etc.

## Features

1. Adopting super bright SMD5050, better heat dissipation and longer lifespan.
2. Special lens design, 160°beaming angle and light evenly
3. Well sealed:anti-dusting, anti-moisture, waterproof, anti-shock, waterproof IP65.
4. CE , RoHS and UL certified.

## Parameters

Items	Parameters
Part Number	ZH03QA5-Q
Beaming Angle (°)	160
CRI (Ra)	≥75
Luminous Flux (lm)	R6 G22 B5
Voltage (V)	DC12
Power (W)	0.65
Dimension (mm)	85*17.5*6.3
Weight (g)	12
Working Tem. (°C)	-25~+60
Storage Tem. (°C)	-25~+70
Protection Grade	IP65

## Dimensions

Unit:mm(in)

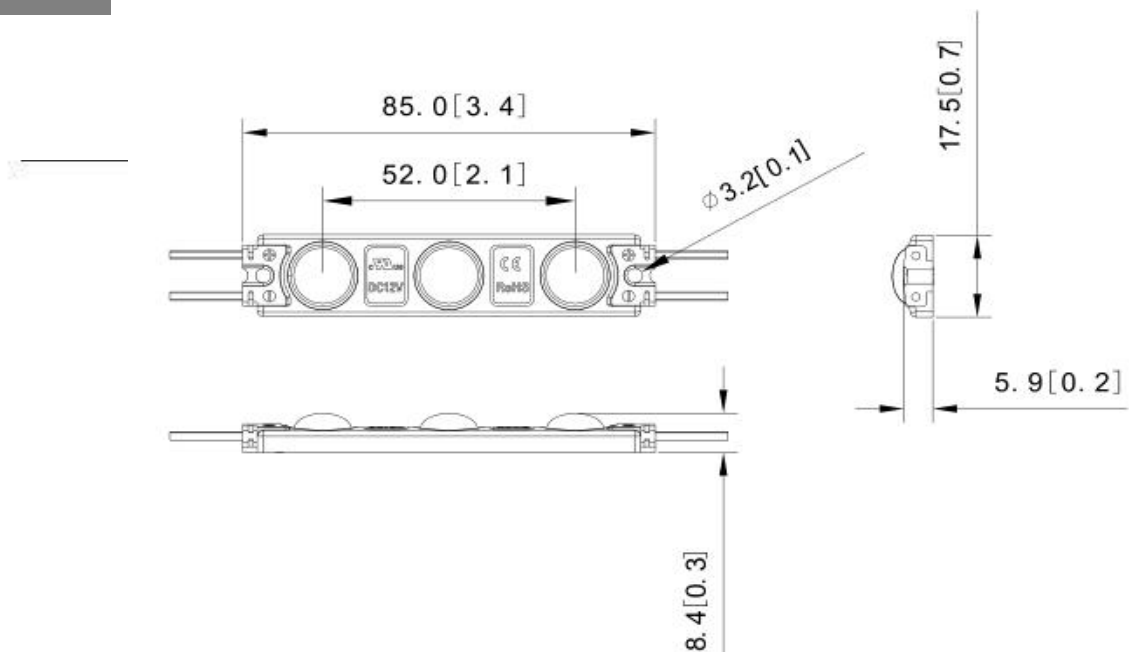

## Beaming Angle

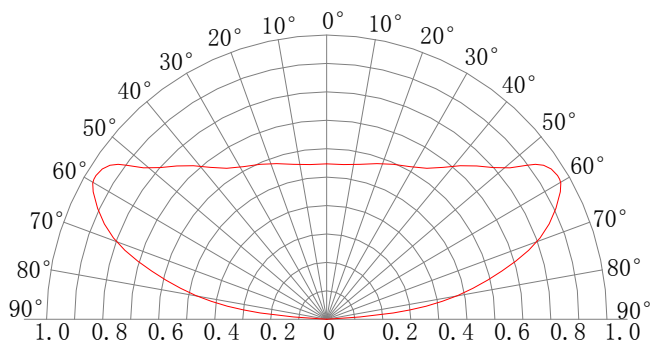

## Reference Scheme

Width (mm)	Depth (mm)	Size (mm)	Square (m <sup>2</sup> )	Distance (mm)	Qty (pcs)	Density (pcs/m <sup>2</sup> )	Illumination (lux)
A50	60	510*480	0.24	120	18	75	4800-7100
A65	80	670*640	0.42	150	22	52	4100-5400
A90	100	840*810	0.68	180	25	37	2900-4500
A100	120	1020*970	0.98	200	28	29	2800-3600
A130	150	1250*1200	1.5	220	29	19	2000-2400

### Remark:

1. The acrylic plate in the case is 3mm thickness, and the light transmittance is 54.4%.
2. The illumination above is the minimum data when evenly lighted.
3. The above data is for reference only.

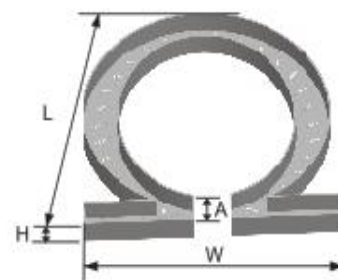

单位: mm(in)

## Wire connection

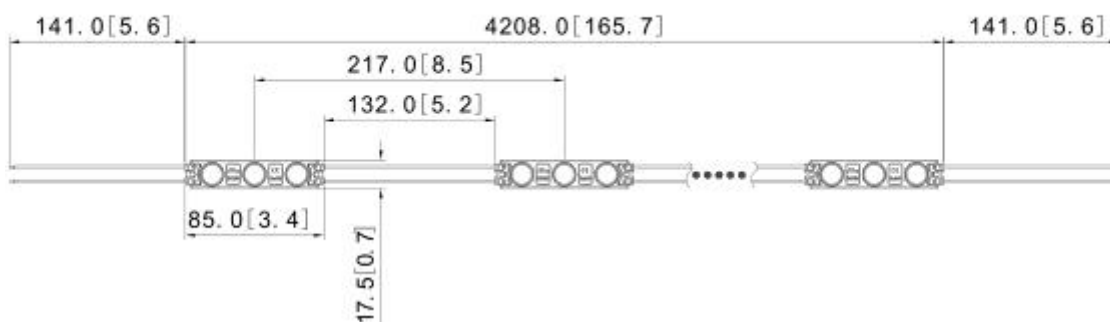

## Packing



50 pcs per string



100 pcs in an antistatic bag



1500 pcs per carton



## Packaging Specification

1. Antistatic bag adopted
2. Packing information

Part Number	ZH03QA5-Q
Carton Dimension(mm)	490*450*220
Bags per carton	10
Quantity per carton(pcs)	1000
Net Weight(kg)	13.5(1±10%)
Gross Weight(kg)	14.84(1±10%)

Due to the packing manner difference, please adhere to the original products in case of discrepancy found between the picture and actual product.

## Warning

1. Disassembling or modifying the product is forbidden.
2. Installation with power on is forbidden.
3. Any organic solvent chemical is forbidden.
4. Acidic or alkaline adhesive is forbidden when install, neutral glass cement could be used for installation purpose, make it drying in open environment for four hours.
5. Isolation and corrosion prevention on all wiring points and wire ends.
6. Make sure the power wire is thick enough and ensure the voltage and connections are connected correctly before power on.
7. This product should be used in a sign, do not expose it in opening site.
8. Installation, maintaining should be done by professional staff.
9. 20 pcs in a serial connection maximum.
10. The power wire between power supply and module should be less than two meters to keep the same brightness on all parts.

## Declaration

1. Warranty: 5 years.
2. In order to ensure the safety, the broken wires needs to be replaced by the manufacturer or the service agent, or by the staff with the similar qualification.
3. The given data in the specification was based on the laboratory testing, there may be discrepancy found in the actual products.
4. The given drawings in the specification are only for reference, there may be discrepancy found in the actual products.
5. The products are subject to change without prior notification.

