

一体式吸料机  
Combined auto loader

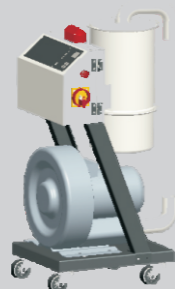

分体式吸料机  
Separate auto loader



欧化吸料机  
Europeanization auto loader



RAL真空填料机系列机型能实现对注塑机的料斗进行自动加料，避免人力搬运，节约人工成本。一体式吸料机主要用于一台填料机对一台注塑机的自动加料，分体式吸料机可实现远距离对塑机的自动加料。各机型均采用不锈钢料斗，确保原料不受污染。采用高压风机，具有吸力强，操作简单，安装简便等特点，是塑料工业中被广泛应用的原料输送设备。可选配两料比例阀，实现两种不同塑料颗粒对一台注塑机的自动填料

RAL series vacuum auto loader can feed material to injection molding machine hopper automatically, to avoid manual handling and save labor cost. Combined auto loader mainly used for one set of auto loader feeding material automatically to one set of injection molding machine. Separate auto loader can feed material automatically to injection molding machine for long distance. All auto loaders adopt to stainless steel hopper, to avoid without pollution of raw materials. Adopt to high pressure blower, It has the characteristics of strong suction, simple operation and easy installation, Optional purchase with the ratio valve of two material materials, can feed two different plastic granules automatically to an injection molding machine.

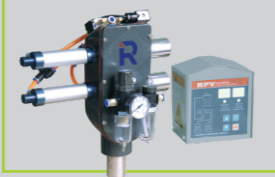

两料比例阀  
ratio valve of two material materials



宁波北仑日宏机械制造有限公司  
Ningbo Beilun Rhong Machinery Manufacturing Co.,Ltd

地址：浙江.宁波.北仑.小港街道.东岗碶.  
Donggangqi,Xiaogang Subdistrict,Beilun,  
Ningbo,Zhejiang Province,China.  
T +86-574-55019010 ,0086-137 7723 9417  
F +86-574-55019017  
E-mail:rhong@plastic-auxiliary-equipment.com



Wechat



Website

更多咨询请访问：[www.rhongmachinery.com](http://www.rhongmachinery.com) (EN)

一体式吸料机  
Combined auto loader  
分体式吸料机  
Separate auto loader  
欧化吸料机  
Europeanization auto loader

Vacuum auto-loader series  
真空填料机系列

RAL系列自动填料机均采用不锈钢料斗，高效率真空马达，并装有马达过载保护装置及缺料自动报警器，兼具轻便耐用、吸力强、安装简便、操作容易等特性

RAL series auto-charging machine uses stainless steel charge basket and high-efficiency vacuum motor and motor overload protection device and material shortage auto-alarming device, it has the characters of light and durable, strong suck force, simple and easy for installation, and operation.



RAL300U/450U



RAL300I/403I



RAL-P



RAL-E

不锈钢储料桶，轻便耐用好清料。  
马达配有过载保护装置。  
微电脑控制运转，操作简单。  
独立滤清器装置，方便清除积尘。  
静音装置，减低运转噪音。  
缺料自动蜂鸣警报保护装置

- Stainless steel charge basket, light, durable, easy for material clean.
- The overload device on motor.
- Computer control operation, simple and easy for operation.
- Independent filter cleaner, convenient for accumulated dust cleaning.
- Quiet device, reduce the operation noise.
- The material shortage auto-alarming protection device.

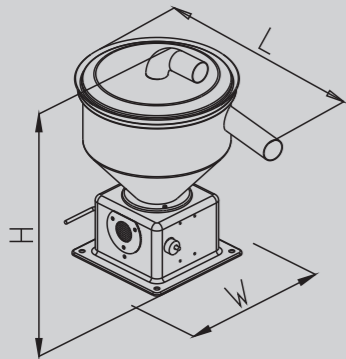

RAL-P

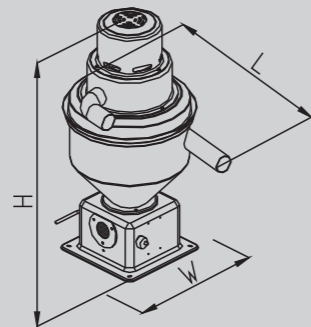

RAL300I/403I

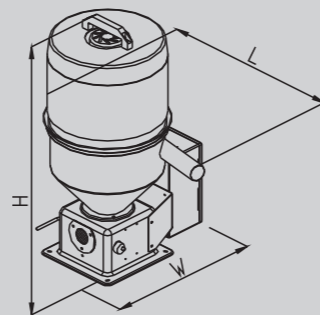

RAL300U/450U

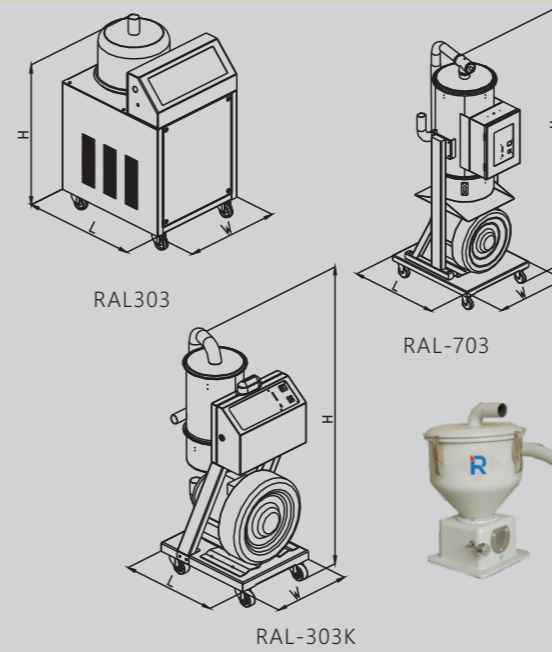

规格表 Specifications

机型 Model	马达 Motor		输送能力 Conveying capacity(kg/hr)	料斗量 Capacity of charge basket(L)	输料管内径 Inside diameter of conveying(mm)	外形尺寸 External size(mm)		重量 Weight (kg)	
	形式 Type	规格 Specification				主体 Main body HxLxW	料斗 Hopper HxLxW	主体 Main body	料斗 Hopper
RAL-300I	碳刷式 Carbon Brush	1100W 1φ	300	6	φ38	550X400X350	—	11	—
RAL-403I	感应式 Induction	1.5HP 3φ	400	10	φ38	800X450X450	—	25	—
RAL-300U	碳刷式 Carbon Brush	1200W 1φ	300	6	φ38	500X400X760	—	13	—
RAL-450I	碳刷式 Carbon Brush	1500W 1φ	450	6	φ38	500X400X760	—	16	—
RAL-300	碳刷式 Carbon Brush	1100W 1φ	300	6	φ38	550X450X300	450X350X250	16	5
RAL-303	感应式 Induction	2HP 3φ	300	6	φ38	650X450X400	500X450X300	40	6
RAL-503	感应式 Induction	3HP 3φ	550	12	φ38	650X450X400	500X450X300	55	5
RAL-303K	感应式 Induction	2HP 3φ	300	6	φ38	990X530X420	500X450X300	50	6
RAL-503K	感应式 Induction	3HP 3φ	550	12	φ38	990X430X420	800X450X300	60	8
RAL-703	感应式 Induction	4HP 3φ	750	25	φ51	1400X500X500	800X450X300	75	8
RAL-903	感应式 Induction	5.5HP 3φ	900	25	φ51	1400X500X500	800X450X300	80	5
RAL-323	感应式 Induction	2HP 3φ	300	6+6	φ38	750X450X400	450X350X250	45	6
RAL-523	感应式 Induction	3HP 3φ	550	12+12	φ38	750X450X400	450X350X250	55	6
RAL-7.5HP	感应式 Induction	7.5HP 3φ	1000	36	φ51	680X1700X550	980X450X300	115	10
RAL-10HP	感应式 Induction	10HP 3φ	1500	36	φ51	680X1700X550	980X450X300	120	10

产品规格若有变更,恕不另行通知。

Please excuse for not note if some specifications of products are changed.

Note注

- 1) The test condition of conveying capacity: Height 4meters, distance 1 meter.
- 2) All other specification of machines are 3φ 380V 50Hz, except the specification of RAL-300/300I is 1φ 220V 50Hz.
- 3) RAL-P vacuum hopper is standard all location, RAL-E infrared hopper is optional purchase
- 4) "U" means european auto loader, "K" means Open-style auto loader, "I" means combined auto loader

- 1) 输送能力测试条件为：高度4m，水平距离为1m。
- 2) 机器电压规格RAL-300/300I，RAL-300U/450U为1φ 220V 50HZ外，其余均为3φ 380V 50HZ。
- 3) 标配料斗为RAL-P真空料斗，可以选配RAL-E电眼料斗。
- 4) "U"为欧化吸料机,"K"为敞开放式吸料机,"I"为一体式吸料机