

DSY Holding Co.,Ltd.

Hebei Dongshengyuan Trading Co., Ltd.

Hebei Bangda Metal Products Co., Ltd.

Add.:Floor 9th, 21st Building, Hanlinguantianxia, Hongqi Street, Qiaoxi District, Shijiazhuang, Hebei, China

Aluminum Formworks System

Tina

Mobile:008615930168395

Web:www.hbdsy.com /www.wirenettingfactory.com

www.hbdongshengyuan.en.alibaba.com

E-mail: dsyfactory12@hbdsy.com

Skype: [dsyfactory12@hotmail.com](https://www.skype.com/people/dsyfactory12@hotmail.com)

Wechat :huan19901128

1. Product Description:

Aluminum formwork system panel also called aluminum alloy formwork panel. It is made of the overall extrusion forming of aluminum alloy. Aluminum formwork system is suitable for the high degree of standardization tall buildings or multi-layer buildings and villas.

Material: 6061 -T6



2. Advantage & Disadvantage

Advantage:

1. Short construction.
2. Turns more and good economic benefit.
3. Lighter weight, Construction more easily, conveniently and effectively.
4. Good stability, high bearing capacity.
5. The wide scope of application.
6. Little flat-fell seam, high precision. Good surface after dismantling.
7. Independent support system & tidy.
8. Standard and highly optimized for general use.
9. High Recyclable Value.
10. Conform to the Low-Carbon Economic requirements.



3.Product Frames-

Panel System, Accessories System, Support System, Fasten System

Panels: The sealing surface of the concrete structure construction required, Ensure that the concrete construction structure forming.

Including: Wall Panel & Top-Panel.

Wall Panel : abbr. P Eg: P15210, W:150mm L: 2100mm

Common Specification:

P40240 W 400mm × L 2400mm ,

P20210 W 200mm × L 2100mm

P15180 W 150mm × L 1800mm ,

P15150 W 150mm × L 1500mm

P10120 W 100mm × L 1200mm ,

P05100 W 50mm × L 1000mm



Top-Panel
Adjust the height of the wall.
W: 100mm~300mm



Beam
•• Beam & Beam
Soffit

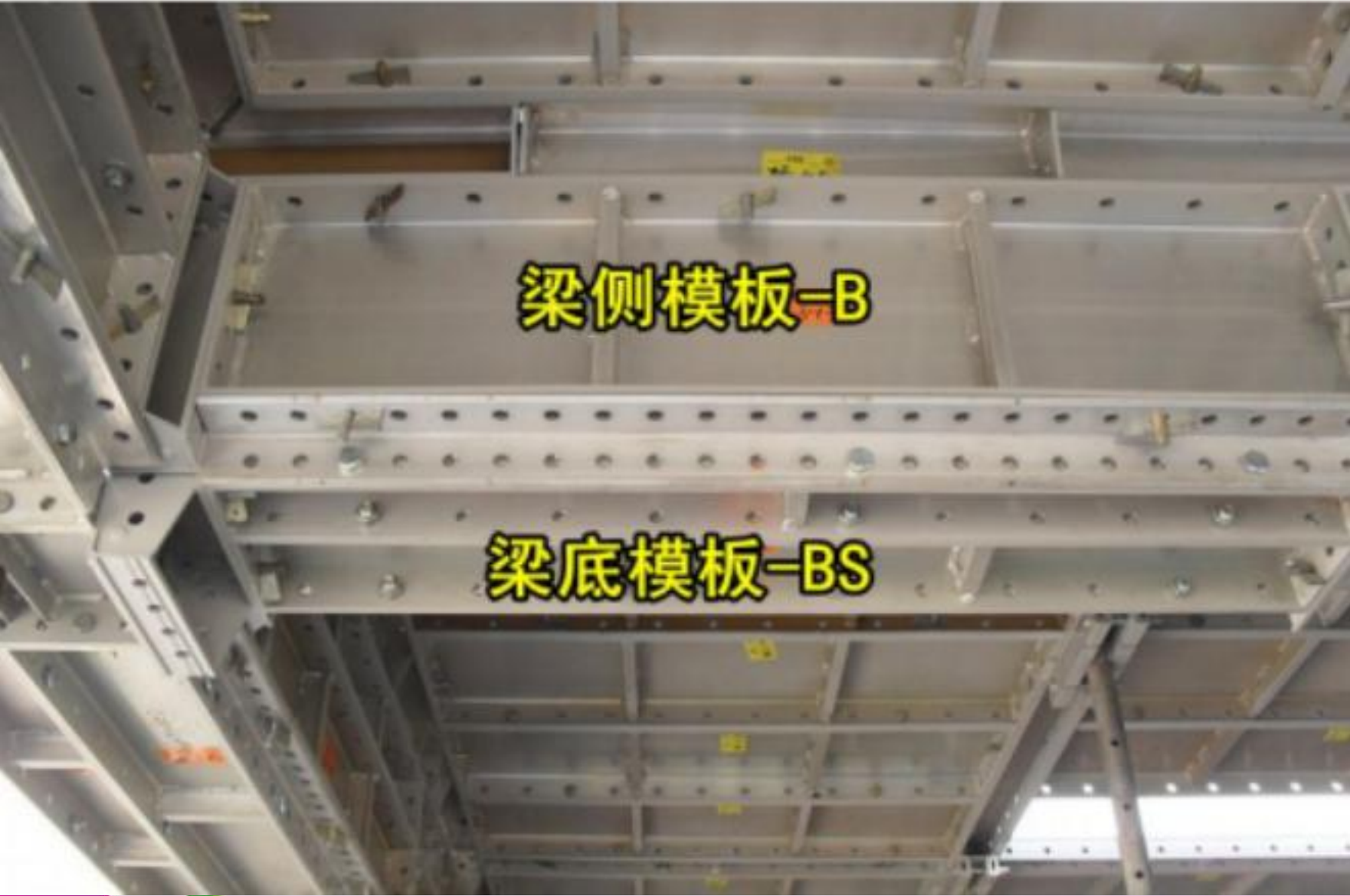

梁侧模板-B

梁底模板-BS

Deck- Panel: Use for top's plate. Also called Building template



EXTERNAL CORNER Abbr. EC. Mainly used for the corner connection of the wall formwork, Also the beams's corner are connected

Regular Specific.:

EC1500 65mm × 65mm × 1500mm,
EC1000 65mm × 65mm × 1000mm,

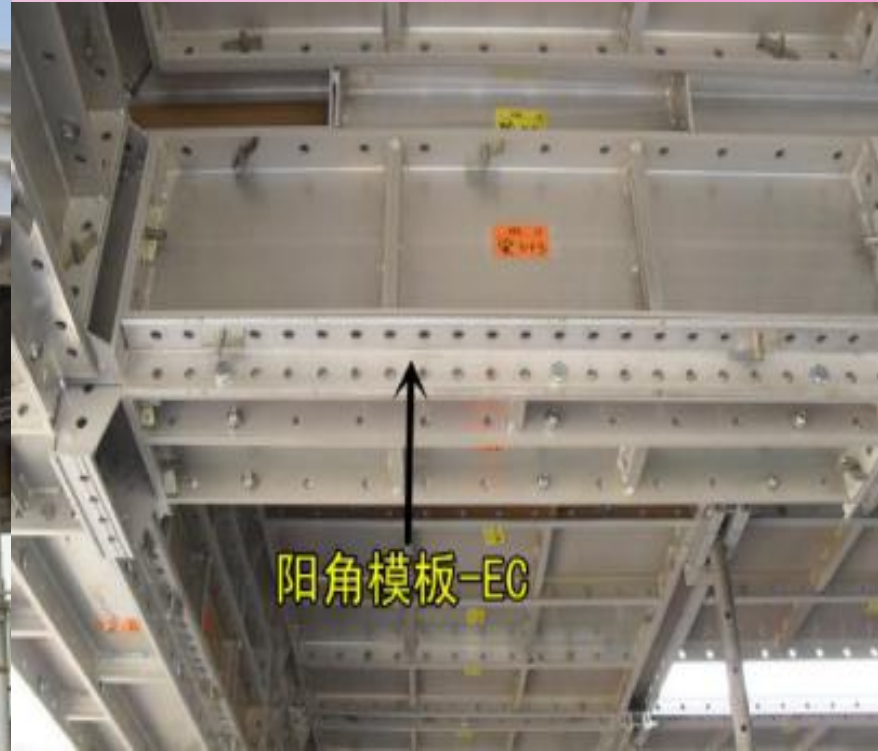

3) **External Corner:** - It forms the external corner of the formwork system.

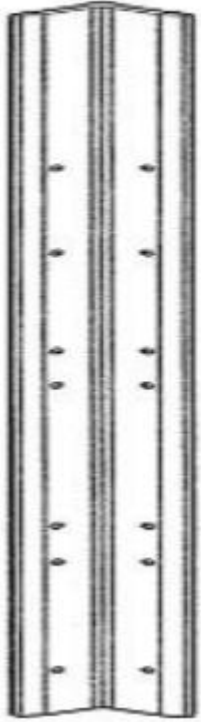

阴角模板 (I C):

IC -- Internal Corner

SC -- Soffit Corner

SL -- Soffit Length

LS -- Length Soffit

Regular Specific.:

IC2400 100mm*100mm*2400mm,

SL2100 100mm*100mm*2400mm,

IC1800 100mm*100mm*1800mm

SL1500 100mm*100mm*1500mm

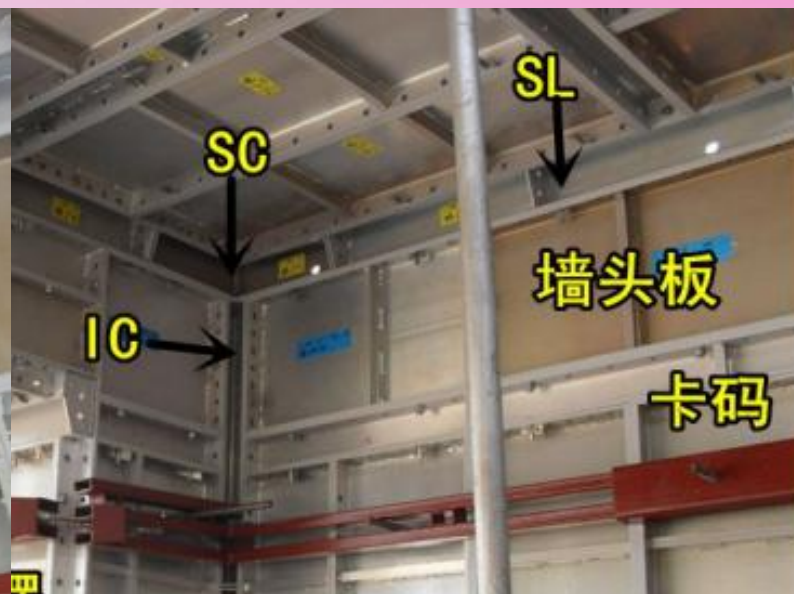
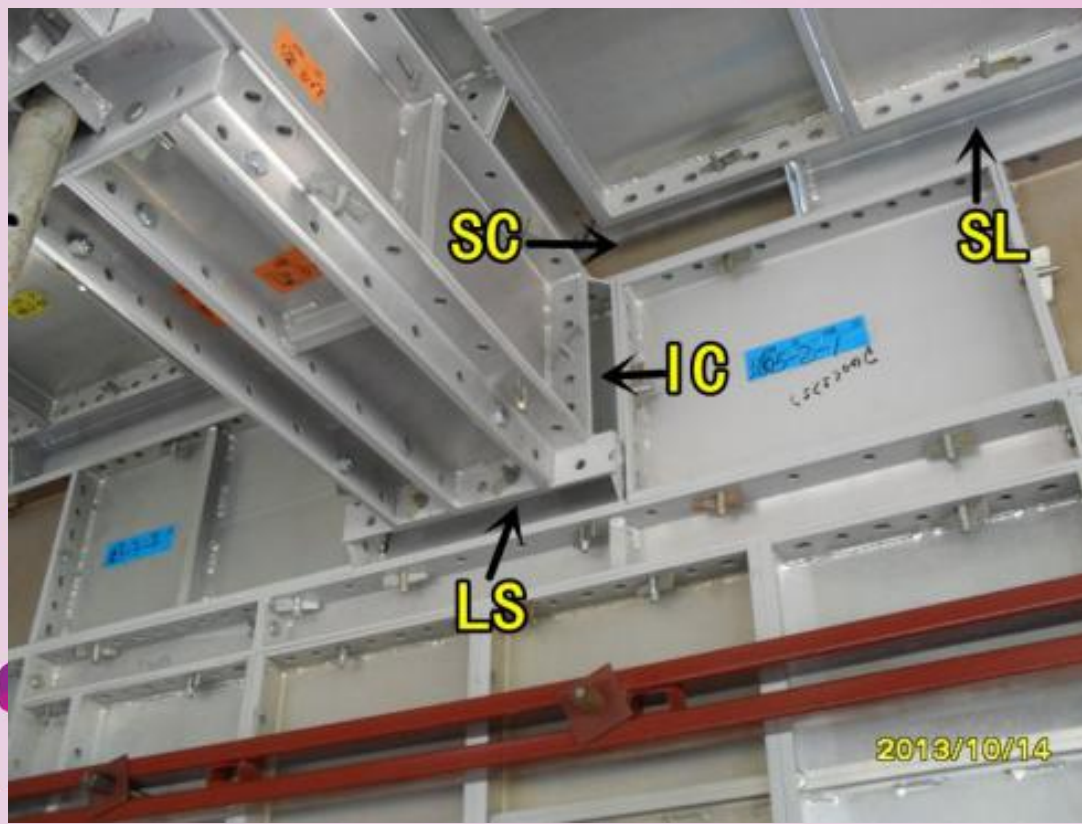

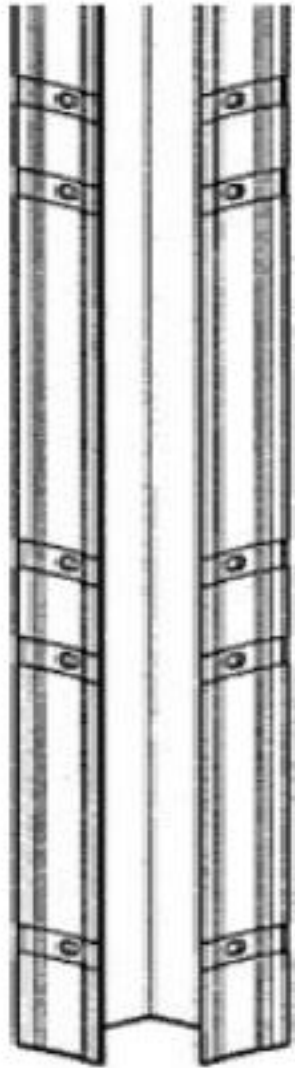

内外阴角

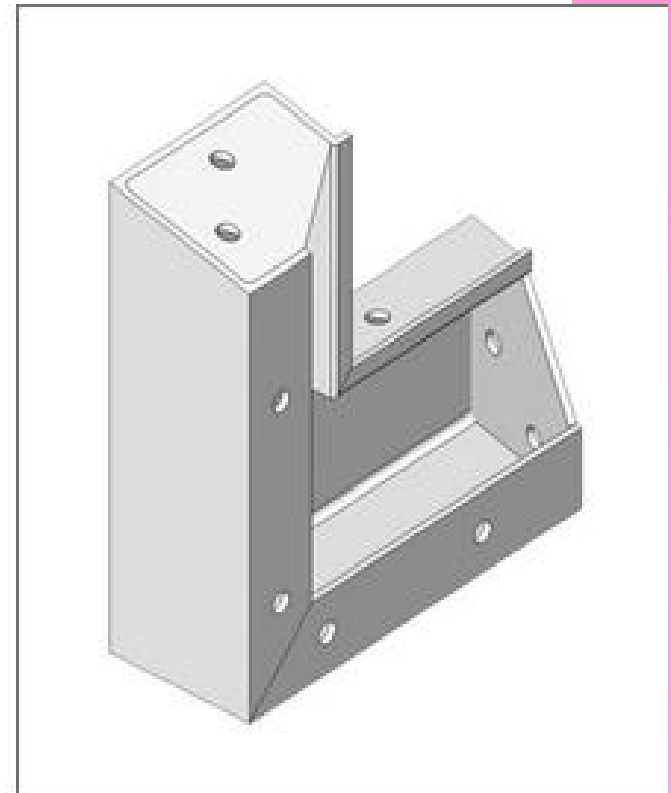

拐角横梁

FIG 3.18: - INTERNAL CORNERS

Support System: Supporting function in the construction of concrete structure

Beam prop Abbr.: BP

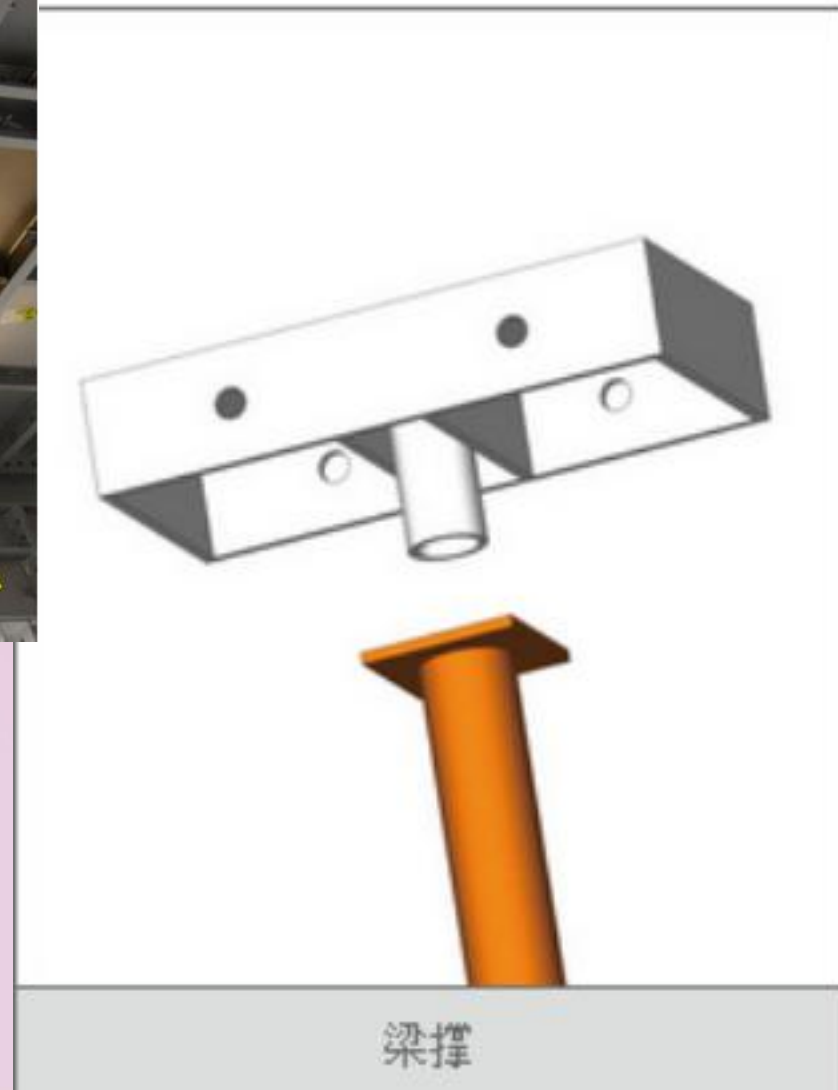

Deck-Prop Abbr. DP

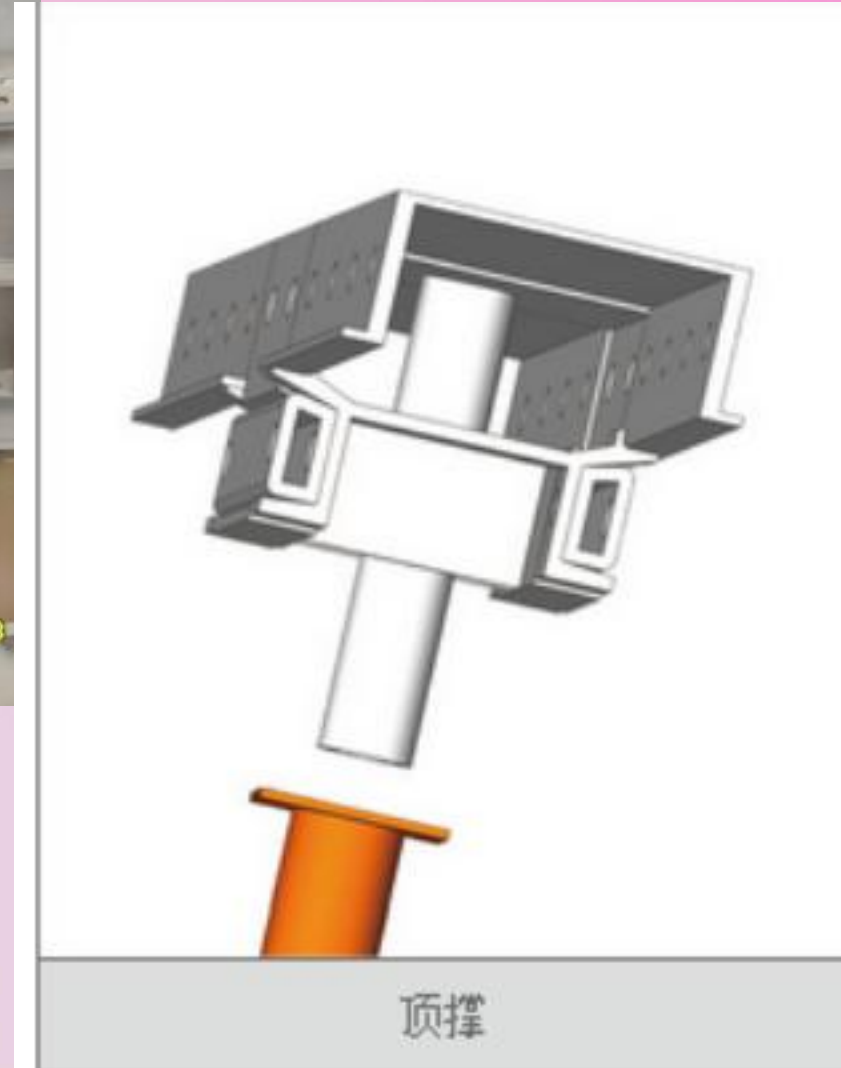

Support Piece ----- Independent support
Distance: 1200mm or 1000mm per PC

Hebei Dongshengyuan Co., Ltd.

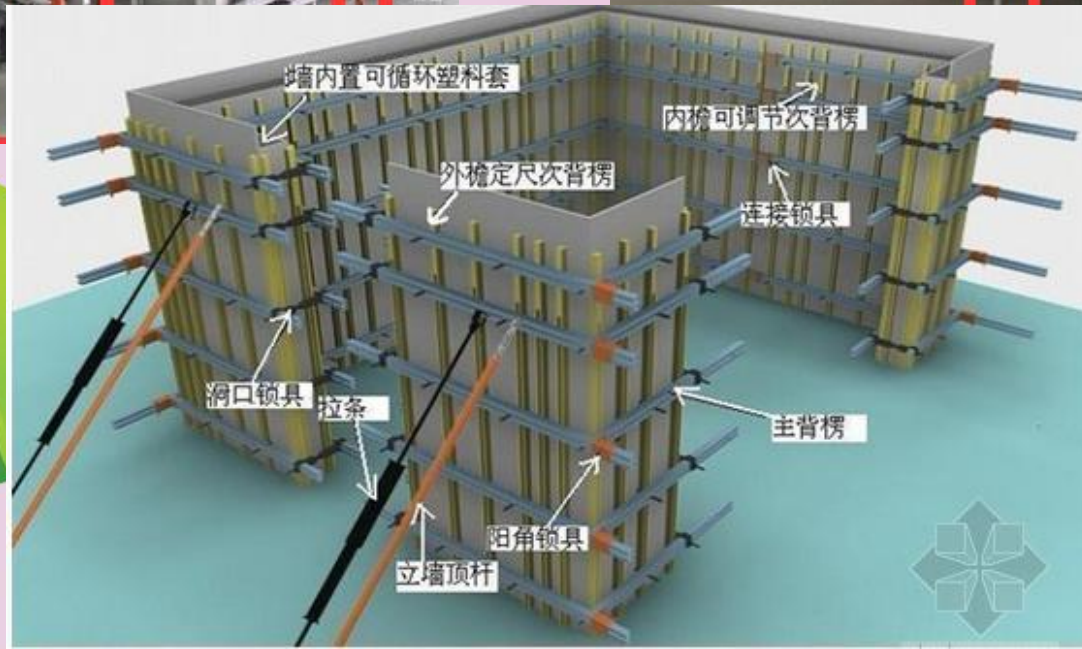

Beam: MID Beam & End Beam

Mid Beam: With oblique section and support in two sides. Abbr. MB

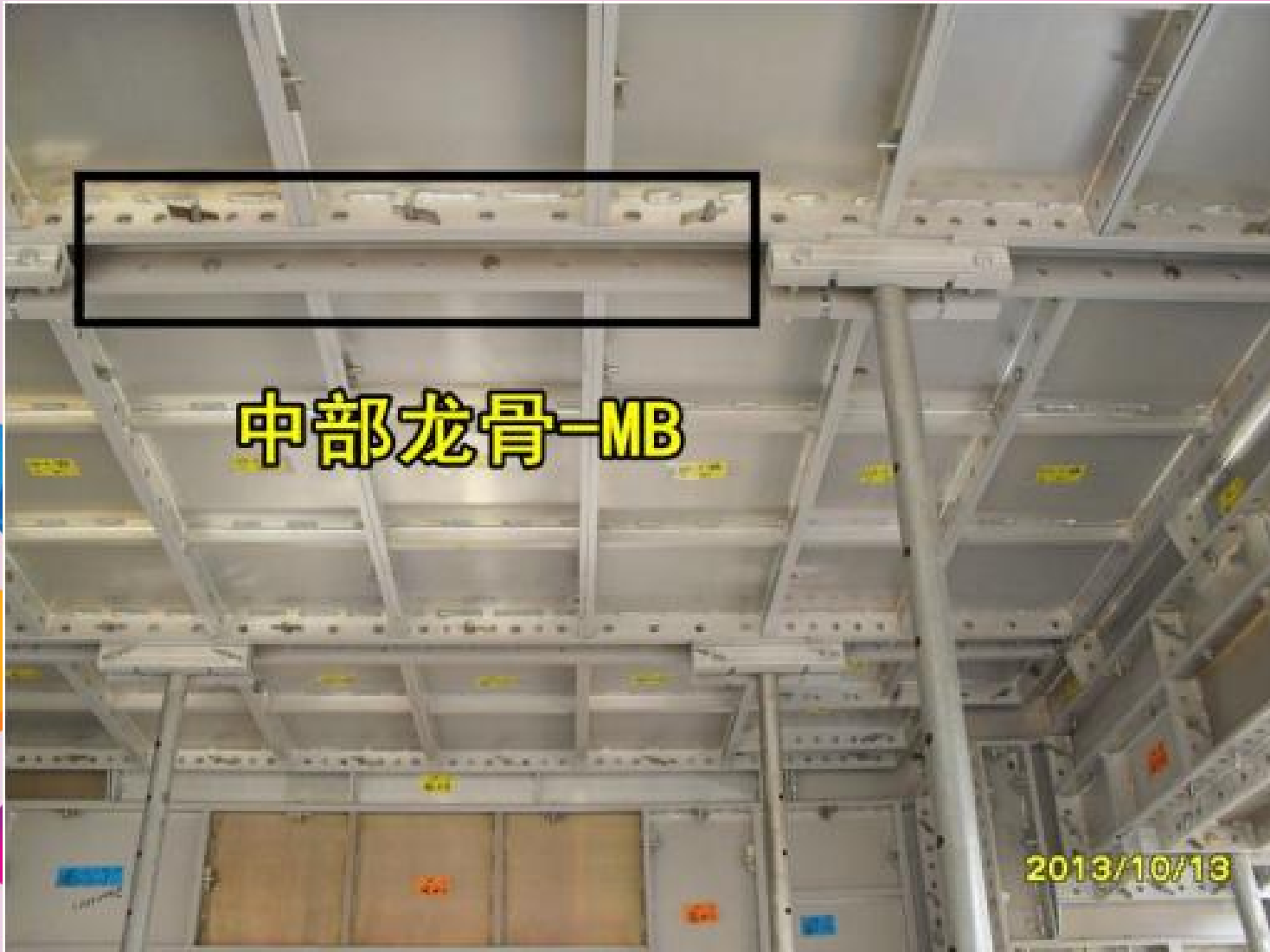

End-Beam: With oblique section and support only side, the other side with brad hole's wall and floor IC of connection

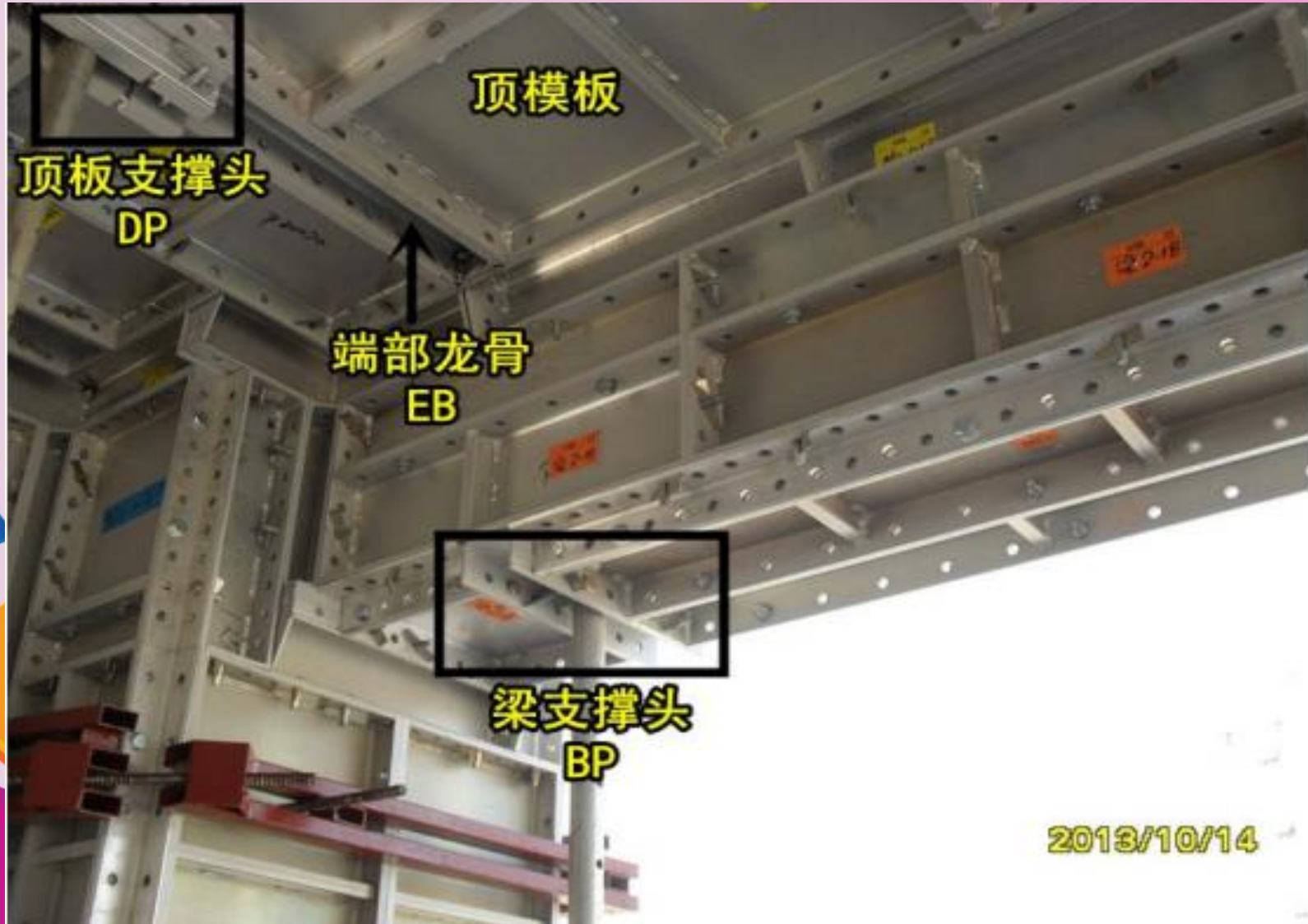

KICKER PANEL Abbr. : K formwork



KICKER PANEL

engyuan Co., Ltd.

导墙板-K板

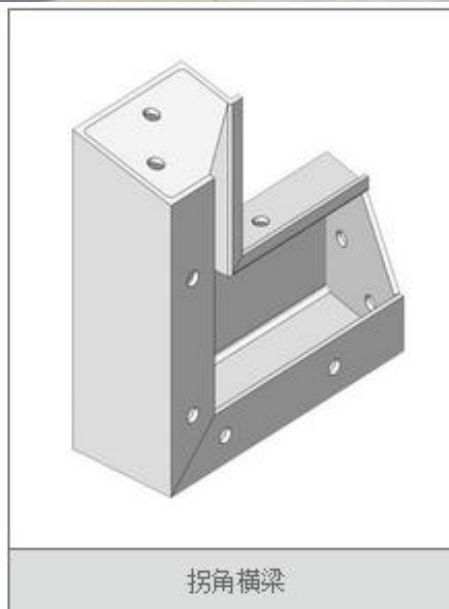
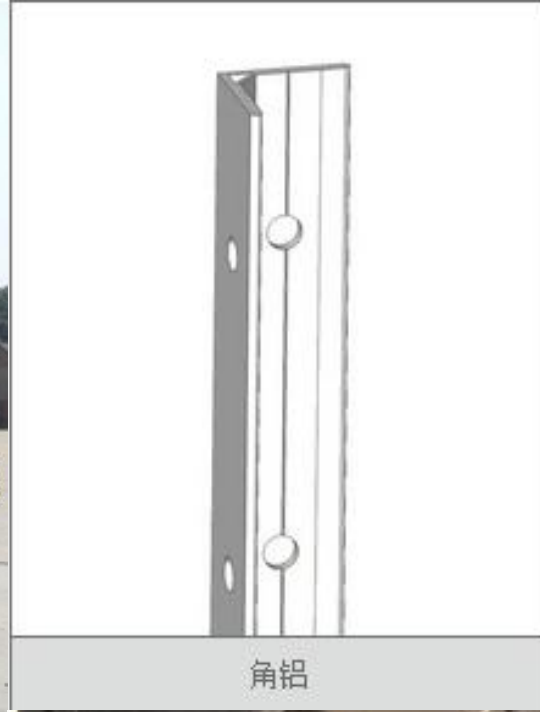
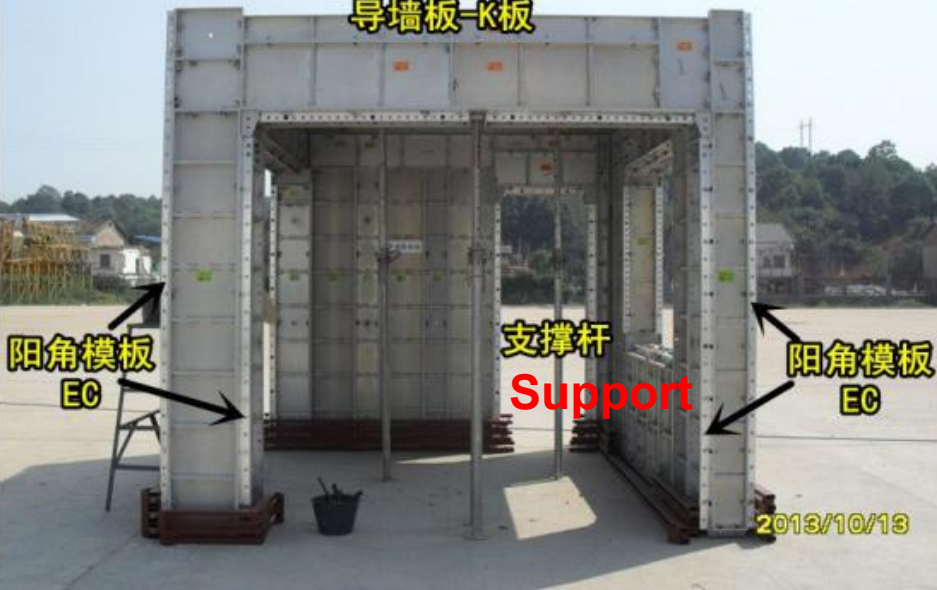

Accessories System : Including: brad, brad piece, bolte etc.



Toggle



Fasten System : To ensure that the structure width of the template molding, in the process of pouring concrete does not produce deformation, the template does not appear up mode, burst mode phenomenon. Mainly including connectors, wall screw, back edge etc.



Pull screw rod with casing pipe
带套管的对拉螺杆



Ending Wall
墙模紧固背楞



Bolt

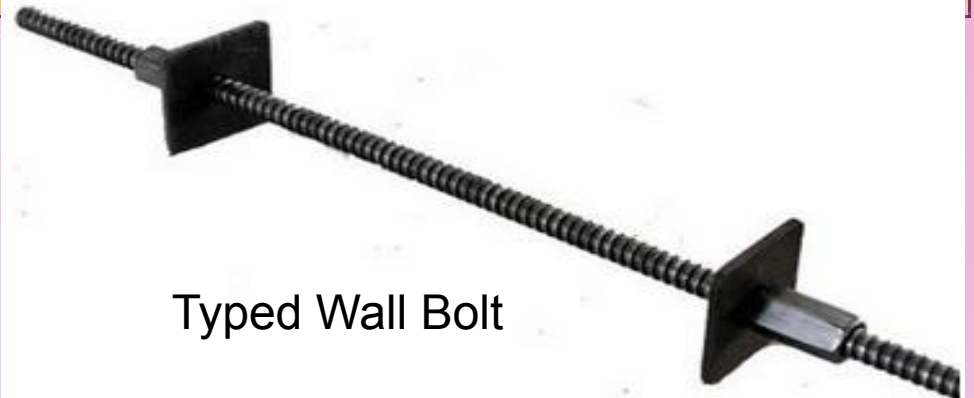

Typed Wall Bolt

Construction process:

Jointing formwork --- wall formwork--- beam forms---- stair formwork ----
concreting --- quality checking---- formwork-stripping



5. Summary



Wall



Column



Staircase



Beam



Shoring



Slab



After stripping



After stripping



After stripping



7.Packaging

模板出货打包



装柜



8. Field installation





THANK YOU

Make Presentation much ore fun

