

Resilient Seated Sluice/Gate Valve

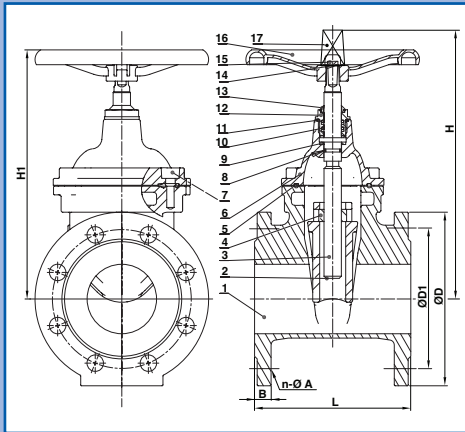

PIPESOL
UK LTD



MATERIALS

ITEM	PARTS	MATERIAL
1	Body	QT 450-10 BS EN 1563 EN-GJS-450-10
2	Disc	QT450-10 BS EN 1563 EN-GJS-450-10
3	Stem	SS420
4	Disc Nut	Brass
5	Bonnet Gasket	EPDM Rubber, ESW-70 WRAS Listed
6	Bonnet	QT450-10 BS EN 1563 EN-GJS-450-10
7	Bolt	Galvanised Steel
8	O-Ring	EPDM Rubber, ESW-70 WRAS Listed
9	Trust Ring	Brass
10	O-Ring	EPDM Rubber, ESW-70 WRAS Listed
11	O-Ring	EPDM Rubber, ESW-70 WRAS Listed
12	Bushing	Brass
13	Dustproof Ring	EPDM Rubber, ESW-70 WRAS Listed
14	Washer	Galvanised Steel
15	Bolt	Galvanised Steel
16	Handwheel	QT450-10 BS EN 1563 EN-GJS-450-10
17	Stem Cap	QT450-10 BS EN 1563 EN-GJS-450-10



SPECIFICATION

DN	DN50 - 600
PN (BS EN 1074 - 1&2)	PN 10 / PN 16
DESIGN STANDARD	BS5163
FACE TO FACE LENGTH	DIN 3202 - F4/F5
END FLANGE	BS 4504 / BS EN 1092 - 2 • GB / 17241. 6 . ISO 7005. 2
TEST	BS EN 1074 - 2 • GB / T 13927
APPLICABLE TEMPS	< 80° C

DIMENSIONS (PN10)

DN (mm)	LENGTH F4	F5	Ø D (mm)	Ø D1 (mm)	H (mm)	H1 (mm)	B (mm)	n-Ø A (mm)	SIZE OF BOLT	WEIGHT (Kg)
50	150	250	165	125	277	227	19	4 - Ø 19	M16	9
80	180	280	200	160	326	276	19	8 - Ø 19	M16	14.2
100	190	300	220	180	364	314	19	8 - Ø 19	M16	18.6
150	210	350	285	240	452	402	19	8 - Ø 23	M20	36.2
200	230	400	340	295	538	487	20	8 - Ø 23	M20	58.4
250	250	450	395	350	805	755	22	12 - Ø 23	M20	85.4
300	270	500	445	400	818	768	24.5	12 - Ø 23	M20	132
350										182.6
400	310	600	565	515	1049	999	24.5	16 - Ø 28	M24	262.4
450										345
500	350	700	670	620	1257	1207	26.5	20 - Ø 28	M24	385
600	390	800	780	725	1405	1355	30	20 - Ø 31	M27	527

DIMENSIONS (PN16)

DN (mm)	LENGTH F4	F5	Ø D (mm)	Ø D1 (mm)	H (mm)	H1 (mm)	B (mm)	n-Ø A (mm)	SIZE OF BOLT	WEIGHT (Kg)
50	150	250	165	125	277	227	19	4 - Ø 19	M16	9
80	180	280	200	160	326	276	19	8 - Ø 19	M16	14.2
100	190	300	220	180	364	314	19	8 - Ø 19	M16	18.6
150	210	350	285	240	452	402	19	8 - Ø 23	M20	36.2
200	230	400	340	295	538	487	20	12 - Ø 23	M20	58.4
250	250	450	405	355	805	755	22	12 - Ø 28	M24	85.4
300	270	500	460	410	818	768	24.5	12 - Ø 28	M24	132
350										182.6
400	310	600	580	525	1049	999	28	16 - Ø 31	M27	262.4
450										345
500	350	700	715	650	1257	1207	31.5	20 - Ø 34	M30	385
600	390	800	840	770	1405	1355	36	20 - Ø 37	M33	527



SHANDONG PIPESOL FLOW EQUIPMENT CO., LTD

T Direct Line +81 (0) 15864590268 **T Main Line** +81 (0) 0536-6350678

E richard@sinopipesol.com **W** www.sinopipesol.com



PIPESOL
UK LTD
www.sinopipesol.com