



SHENZHEN BEST LED OPTO-ELECTRONIC CO.,LTD

# TOP LED:3528WW-30K8L3W (3528 SMD LED-Warm White)



	<p>ATTENTION OBSERVE PRECAUTIONS ELECTROSTATIC SENSITIVE DEVICES</p>
--	--



CUSTOMER APPROVED SIGNATURES	SALES APPROVED	APPROVED BY	CHECKED BY	PREPARED BY

## 1. Features

- Emission Color :3000k Warm White LED
- Colloid Color: Yellow Diffused
- High Luminous LEDS
- Low forward voltage
- Meet ROHS, Green Product
- Compatible With Infrared Reflow Solder And Wave Solder Process

## 2. Package Profile & Soldering PAD Suggested

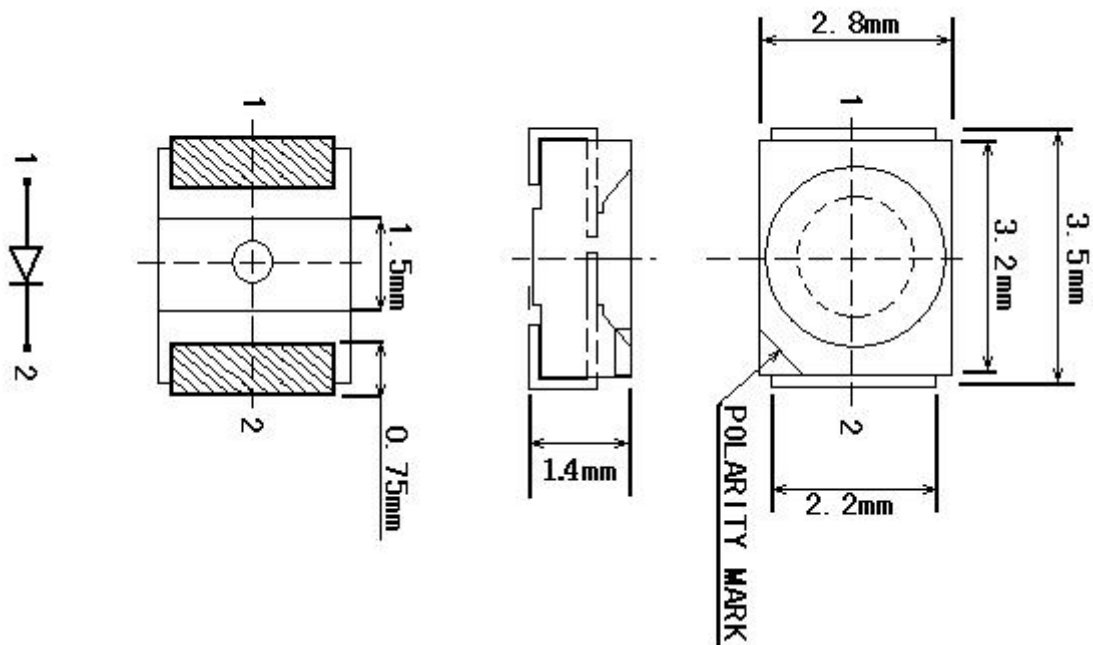

- Notes:
1. All dimensions are in millimeters ;
  2. Tolerance is  $\pm 0.10$  mm unless otherwise noted.



### 3. Absolute Maximum Ratings At Ta=25°C

Parameter	Symbol	Rating	Unit
Power Dissipation	Pd	105	mW
Pulse Forward Current	IFP	100	mA
Forward Current	IF	30	mA
Reverse Voltage	VR	5	V
Junction Temperature	Tj	110	°C
Operating Temperature	Topr	-40 ~ +80	°C
Storage Temperature Range	Tstg	-40 ~ +100	°C
Soldering Temperature	Tsol	260	°C
Electro-Static-Discharge(HBM)	ESD	1000	V
Service life under normal conditions	Time	80000	H
Warranty	Time	5	Years
Antistatic bag	Piece	2000	Back

\*Pulse Forward Current Condition:Duty 1% and Pulse Width=10us.

\*Soldering Condition:Soldering condition must be completed with 3 seconds at 260°C

**4. Electrical Optical Characteristics At Ta=25°C**

Parameter	Symbol	Min	Typ	Max	Unit	Test Condition
Forward Voltage	VF	2.9		3.0	V	IF=20mA
		3.0		3.1		
		3.1		3.2		
		3.2		3.3		
		3.3		3.4		
Luminous Intensity	IV	2000		2800	mcd	IF=20mA
Luminous Flux	$\Phi_{v1}$	7		8	lm	IF=20mA
		8		9		
Color Rendering Index	Ra	80				IF=20mA
Color Temperature	Tc	2800		3200	K	IF=20mA
CIE 1931 Coordinate	X/Y		X:0.43 Y:0.42			IF=20mA
Half Width	$\Delta\lambda$		15		nm	IF=20mA
Viewing Half Angle	2 $\theta_{1/2}$		±60		deg	IF=20mA
Reverse Current	IR			5	uA	VR=5V
Rise Time	tr		15		ns	IF=20mA
Fall Time	tf		15		ns	IF=20mA

\*Luminous Intensity is measured by ZWL600.

\* $\theta_{1/2}$  is the off-axis angle at which the luminous intensity is half the axial luminous intensity.

\* $\lambda_p$  is derived from the CIE chromaticity diagram and represents the single wavelength which defines the color of the device.

**5. Typical Electrical-Optical Characteristics Curves**

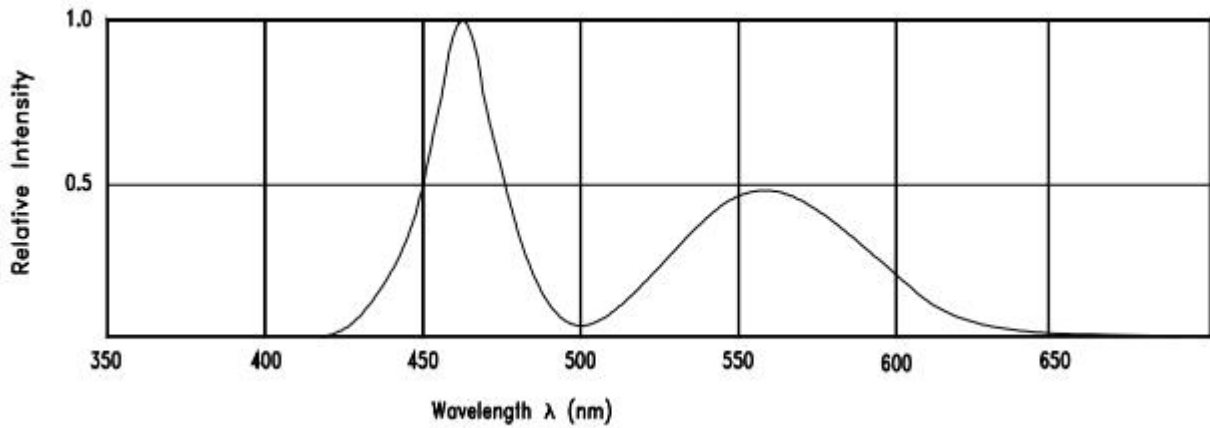

**Fig.1 Relative Intensity vs. Wavelength**

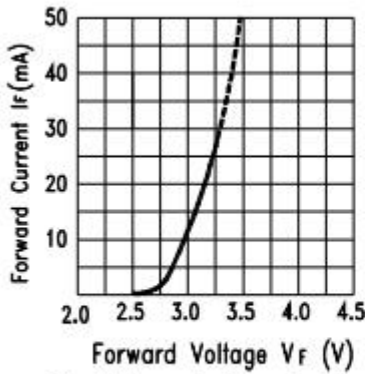

**Fig.2 Forward Current vs. Forward Voltage**

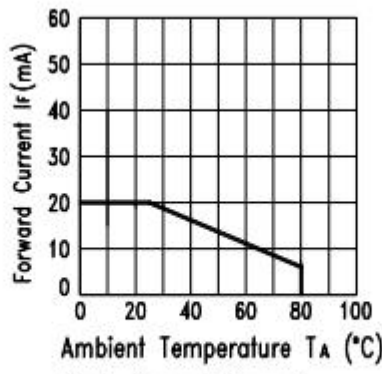

**Fig.3 Forward Current Derating Curve**

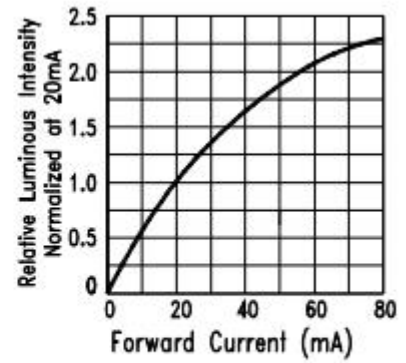

**Fig.4 Relative Luminous Intensity vs. Forward Current**

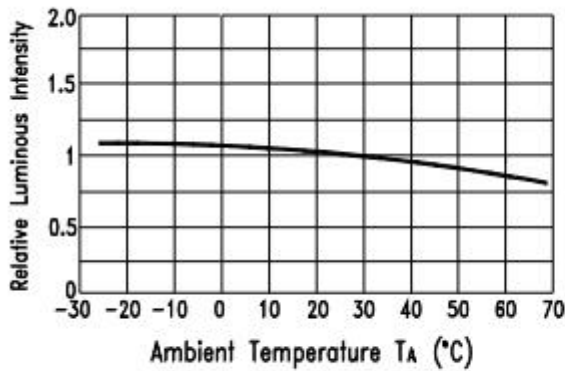

**Fig.5 Luminous Intensity vs. Ambient Temperature**

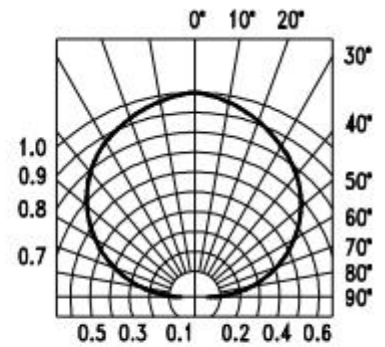
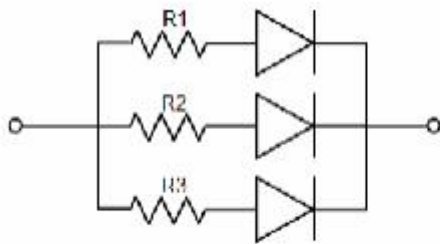

**Fig.6 Spatial Distribution**

## 6. Cautions

### Application

1. A LED is a current-operated device. The slight shift of voltage will cause big change of current, which will damage LEDs. Customer should use resistors in series for the Over-Current-Proof.
2. In order to ensure intensity uniformity on multiple LEDs connected in parallel in an application, it is recommended to use individual resistor separately, as shown in Circuit A below. The brightness of each LED shown in Circuit B might appear difference due to the differences in the I-V characteristics of those LEDs.



**Circuit model A**

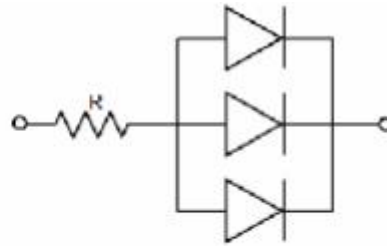

**Circuit model B**

3. High temperature may reduce LEDs' intensity and other performances, so keeping it away from heat source to get good performance is necessary.

### Storage

1. Before opening original package, it is recommended to store them in the following environment:
 

Temperature: 5°C~30°C	Humidity: 85%RH max.
-----------------------	----------------------
2. After opening original package, the storage ambient for the LEDs should be in 5~30°C temperature and 60% or less relative humidity.
3. In order to avoid moisture absorption, it is recommended that the LEDs that out of the original package should be stored in a sealed container with appropriate desiccant, or in desiccators with nitrogen ambient.
4. The LEDs should be used within 168hrs (7 days) after opening the package. Once been mounted, soldering should be quick.
5. If the moisture absorbent material (silica gel) has faded away or the LEDs stored out of original package for more than 168hrs (7 days), baking treatment should be performed using the conditions: 60°C at least 24 hours.

### ESD (Electrostatic Discharge)-Protection

A LED (especially the Blue、White and Green product) is an ESD sensitive component, and static electricity or power surge will damage the LED. ESD-damaged LEDs will exhibit abnormal characteristics such as high reverse leakage current, low forward voltage, or "no light-up" at low currents, etc.

Some advice as below should be noticed:

1. A conductive wrist strap or anti-electrostatic glove should be worn when handling these LEDs.
2. All devices, equipment, machinery, work tables and storage racks, etc. must be properly grounded.



3. Use anti-static package or boxes to carry and storage LEDs. And ordinary plastic package or boxes is forbidden to use.
4. Use ionizer to neutralize the static charge during handling or operating.
5. All surfaces and objects within 1 ft close to LEDs measure less than 100V.

## **Cleaning**

Use alcohol-based cleaning solvents such as IPA (isopropyl alcohol) to clean LEDs if necessary.

## **Soldering**

1. Soldering condition refer to the draft "Soldering Profile Suggested" on page 1.
2. Reflow soldering should not be done more than 2 times.
3. Manual soldering is only suggested on repair and rework. The maximum soldering temperature should not exceed 300°C within 3 sec. And the maximum capacity of soldering iron is 30W in power.
4. During the soldering process, do not touch the lens at high temperature.
5. After soldering, any mechanical force on the lens or any excessive vibration shall not be accepted to apply, also the circuit board shall not be bent as well.

## **Others**

1. The LEDs described here are intended to be used for ordinary electronic equipment (such as office equipment, communication equipment and household applications).Consult BESTSMD's Sales in advance for the applications in which exceptional reliability is required, particularly when the failure or malfunction of the LEDs may directly jeopardize life or health. (such as in aviation, transportation, traffic control equipment, medical and life support systems and safety devices).
2. The light output from the high luminous intensity LEDs may cause injury to human eyes when viewed directly.
3. The appearance and specifications of the product may be modified for improvement without prior notice.