

HSF

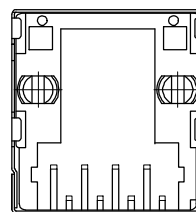
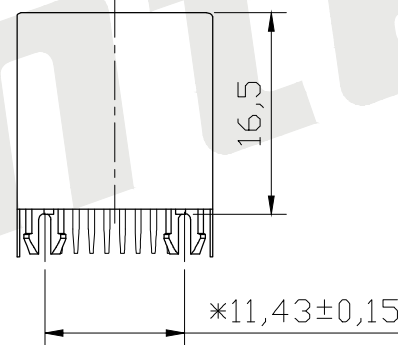
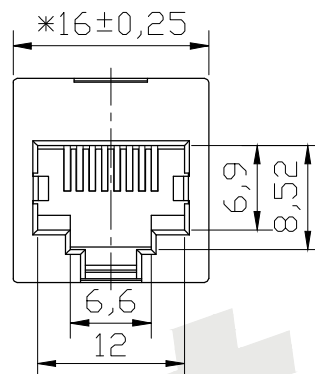
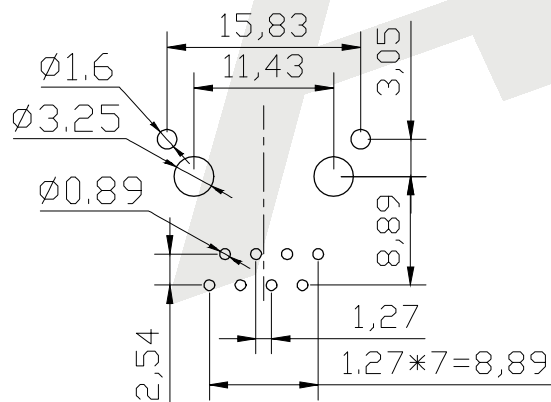
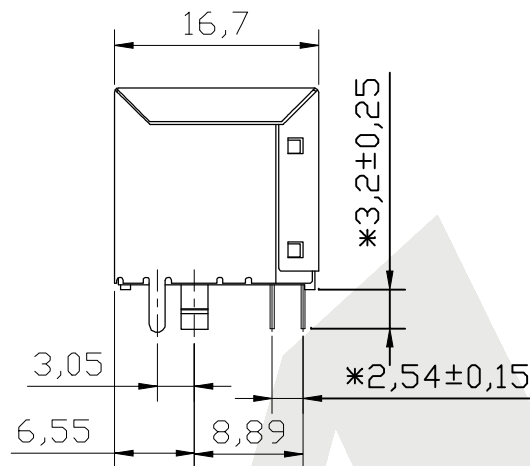

NOTES:

MATERIAL:

- 1. HOUSING MATERIAL :GLASS FILLED POYESTER UL94V-0.
- 2. CONTACT MATERIAL :PHOSPHOR BRONZE t=0.3mm
- 3. PLATING :SELECTING GOLD PLATING 1 μ ~50 μ "OVER NICKEL IN CONTACT AREA. 150 μ " TIN PLATIN. OVER NICKEL IN SOLDER AREA
- 4. SHIELD :0.2mmTHICKNESS COPPER WITH NICKEL PLATEI

ELECTRICAL

- 1. VOLTAGE RATING :125VAC RMS
- 2. CURRENT RATING :1.5AMP
- 3. CONTACT RESISTANCE:30 MILLIOHMS MAX
- 4. INSULATION RESISTANCE 500 MEGOHMS MIN @500V DC
- 5. DIELECTRIC WITHSTANDING RESISTANCE :1000V AC RMS 50Hz. 1MIN

MECHANICAL

- 1. DURRABILITY :750 CYCLES MIN
- 2. PCB RETENTTON PRB-SOLDER :1 LB MIN

REVRONMENTAL

- 1. STORAGE :-40° C TO 85° C
- 2. OPERATION :0° C TO 70° C

Order code:

ATRJ5222 - 8P - 8C - X - D - A
 ① ② ③ ④ ⑤ ⑥

- ① SERIES NO:
- ② NUMBER OF POSITIONS (8P, 6P, 4P)
- ③ NUMBER OF CONTACTS (8C, 6C, 4C)
- ④ Contact PIating
 G0:Gold flash
 G1: 3U" Gold
 G2: 5U" Gold
 G3:10U" Gold
 G4:15U" Gold
 G5:30U" Gold
 SN:Tin
- ⑤ Shield
 A:W/O Shield
 B:Half Shield
 C:Shield W/Eml
 D:Shield W/O Eml
- ⑥ Ports
 A:1X1P
 B:1X2P
 C:1X4P
 D:1X5P
 E:1X6P
 F:1X8P

Unless Otherwise specified tolerance
 X. ±0.35 X.XX:±0.20
 X.X:±0.25 X.XXX:±0.15

SCALE: As Shown UNIT: mm
 DRAW Wu Wu Feng DATE 26/07/2019
 CHECK BobYang DATE 26/07/2019

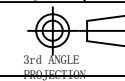

Antenk® ANTENK ELECTRONICS CO., LTD
 Http://www.antenk.com
 E-mail:sales@antenk.com

TITLE: Modular Jack Top entry,
 8P8C, 1X1Port Full shielded

DRAWING NO: ATRJ5222-8P8C-X-D-A

PRODUCT NO: ATRJ5222-8P8C-X-D-A

REV	DESCRIPTION	DATE
1		
2		
3		
4		
5		