

ZGB(P) 系列渣浆泵

Series ZGB(P) Slurry Pump

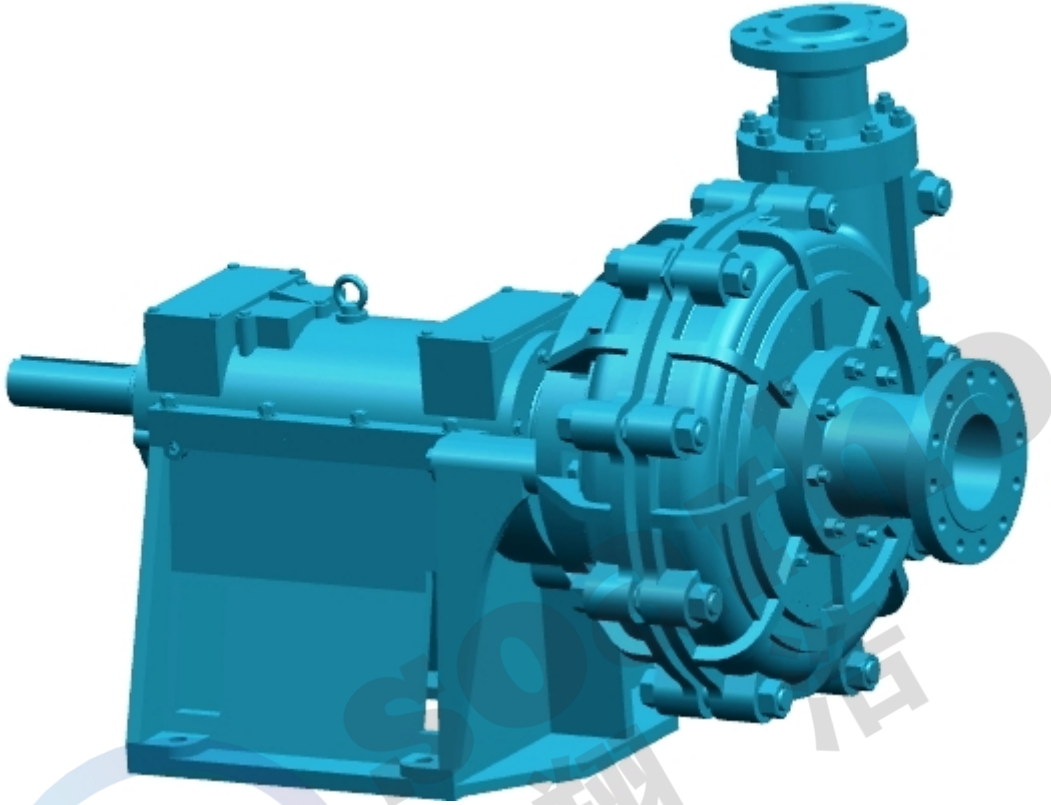

• 公司简介 Enterprise Profile

石家庄翔浩机械有限公司，是以矿山、电力用渣浆泵、脱硫泵、疏浚泵、清水泵为主的工业水泵专业生产企业，集研发、设计、制造、营销、服务为一体，具有严格的质量保证及科学完善的服务体系。

公司技术力量雄厚，拥有资深的水泵设计、制造、应用工程师团队，立足持续为用户带来更大价值，不断提高服务水平与质量。我们不单单向用户提供产品，还可依据客户的工矿需求，采用系统一体化的设计方法，为客户提供渣浆输送的一整套解决方案，使得用户在环保、节能、运营持久、降低产品使用成本等方面取得了显著效果。

公司坚持“技术创新化、管理严格化、生产定制化、服务专业化”的经营理念，全力提升企业现代化管理水平，使企业实现了持续快速发展。

公司的主要产品为ZGB、ZJ、AH、HH、M型渣浆泵、WN型挖泥泵、TL型脱硫泵、G型砂砾泵、SP型液下泵、HDSN型双吸泵、WQ型潜污泵、IS型清水泵等，广泛应用于环境保护工程、污水处理、城市工厂给排水、各种水利工程、冶金、矿山、电力、煤炭、疏浚、采砂、石油化工、建材、火电烟气脱硫等等诸多领域。国内市场占有率逐年递增，国际市场的占有份额

不断提升，产品出口至东南亚、北美、欧洲、中亚、东亚等多个国家和地区。

长期以来，本公司坚持“诚信为本、客户至上”的原则，与众多厂家建立了长期合作关系，并赢得了广大客户的一致好评！

坚信凭借我们更优的产品，完善的服务，良好的信誉，必将赢得更多用户！

Shijiazhuang Soarho Machinery CO.,LTD, is a professional manufacture base of slurry pump, mine pump, FGD pump, dredge pump and clean water pump, combining scientific research, design, manufacture, marketing and service in one, with strict quality control system and science complete service system.

Having strong technical force, the company which has a senior pump design, manufacturing and application engineer team, continues to improves level and quality of service in order to bring greater value to the users. We not only provide products to users, but also provide a complete solution for slurry transportation for user to achieve a significant effect in environmental protection , energy saving , lasting trouble-free operation and cost reduction and so on, adopting a systematic and integrated design method and according to the working condition and the needing of user.

Adhering to the concept of 'technical innovation', 'strict management', 'customized production' and 'professional service', we strive to improve the modern management level and make the enterprises achieve sustained and rapid development.

The main products of the company are ZGB,ZJ,AH,HH,M slurry pumps ,WN dredge pumps , TL FGD pumps, G gravel pumps, SP sump pumps, HDSN double suction pumps. WQ submersible sewage pumps, IS clean water pumps and so on. They are widely used in many fields, such as environmental protection engineering, sewage treatment, municipal factory and water supply and drainage, various water conservancy projects, metallurgy, mine, electric power, coal, dredging, sand mining, petrochemical, building materials, thermal power flue gas desulfurization etc. The share of domestic market is increasing year by year, and the share of the international market is increasing. Products exported to Southeast Asia, North America, Europe, Central Asia, East Asia and many other countries and regions.

For a long time, adhering to the principle of "honesty and customer first", our company has established a long-term cooperative relationship with many manufacturers, and has won the praise of the customers.

Firmly believe that we will win more users by virtue of our better products, perfect service and good reputation.

- **产品介绍 Product Introduction**

ZGB(P)系列渣浆泵为卧式、垂直轴向中开式双泵壳结构，内衬为耐磨金属。叶轮采用高效、高扬程的设计，流道宽畅，抗堵塞性能好。该系列泵结构合理、效率高、运行可靠、维修方便，同时具有大流量、高扬程、可多级串联的特点，广泛适用于电力、冶金、矿山、煤炭、建材、化工等工业部门输送磨蚀性或腐蚀性渣浆。

ZGB(P) series slurry pumps are horizontal, vertical axial middle open type and double casing structure, lined with wear-resistant metal. The Impeller is designed with high efficiency, high head design, and the flow passage is wide, non-clogging. The series of pump has the advantages of reasonable construction, high-efficiency, reliable operation and easy maintenance. In the meantime, the series of pump have the characteristics of flow and high head, and can be multi-stage series. It widely used for handling mixtures containing abrasive and corrosive solids in electric power, metallurgy, mine, coal, constructional material and chemical industry departments.

- **产品特点 Product Feature**

- 1、采用现代CAD设计方法，水力性能优良、效率高和磨损率低。
- 2、轴封采用填料加付叶轮密封和集装式机械密封，适应不同的工况要求。
- 3、轴承组件为水平中开式结构，采用稀油润滑公制轴承，配置有两套轴承冷却系统，必要时可加循环冷却水，保证轴承在低温状态下运行。
- 4、过流部件采用特殊材料，耐磨耐腐蚀性能好。
- 5、可调节叶轮与护板之间的间隙，保证泵的高效运行。
- 6、泵的出口方向可按8个角度旋转安装，以适应不同的现场安装条件。
- 7、允许最大工作压力为3.6MPa，在允许的压力范围内可以多级串联使用，以满足远距离输送要求。

1. CAD modern design, super hydraulic performance, high efficiency and lower abrasion rate.
2. Expeller seal combined with packing seal or mechanical seal adopted to different working conditions.

3. The bearing assembly is a horizontal, medium-open structure. The metric bearing is oil lubrication and is equipped with two sets of bearing cooling system. If necessary, circulating cooling water can be added to ensure the bearing operates at low temperature.
4. Special materials adopted to wet parts, good performance in anti-wearing and anticorrosion.
5. The clearance between the impeller and the cover plate could be adjusted to ensure the pump to operate at high efficiency point.
6. The discharge branch can be positioned at intervals of 45 degree by request and oriented to any eight positions to suit installation and application.
7. The pump can be operated in series with multi-stage within permissible pressure. The permissible maximum working pressure is 3.6MPa.

- **性能范围 Range of Performance**

流量 Capacity Q: 50-1800m³/h
 扬程 Head H: 30-120m
 吐出口直径 Discharge diameter: 65-300mm

- **型号说明 Model Code**

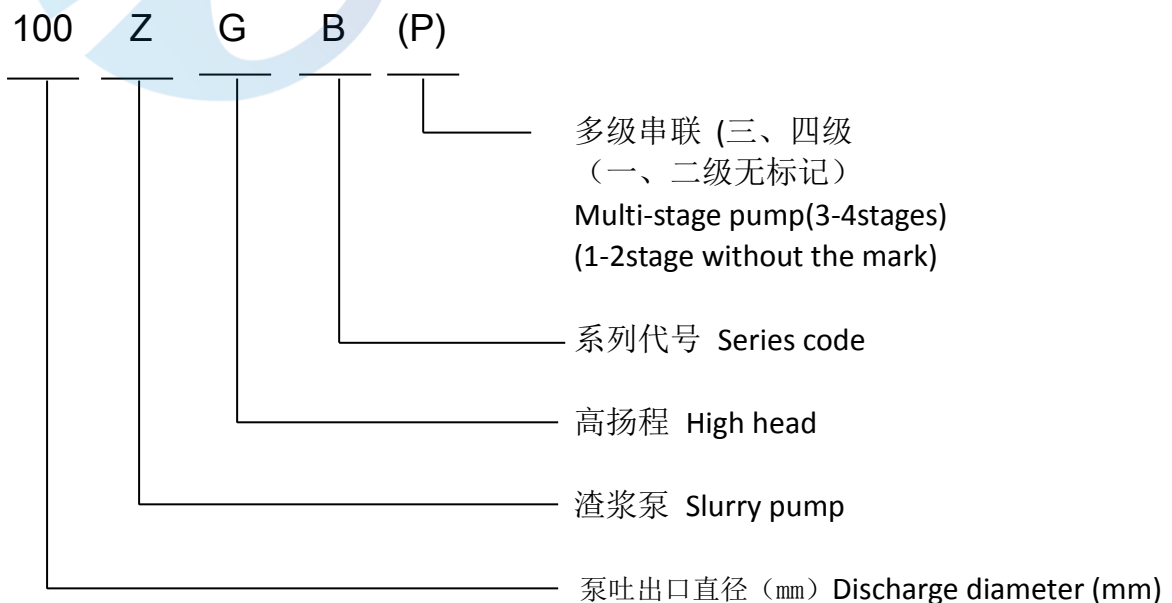

结构图 Construction description

1. ZGB 型渣浆泵 Series ZGB slurry pump

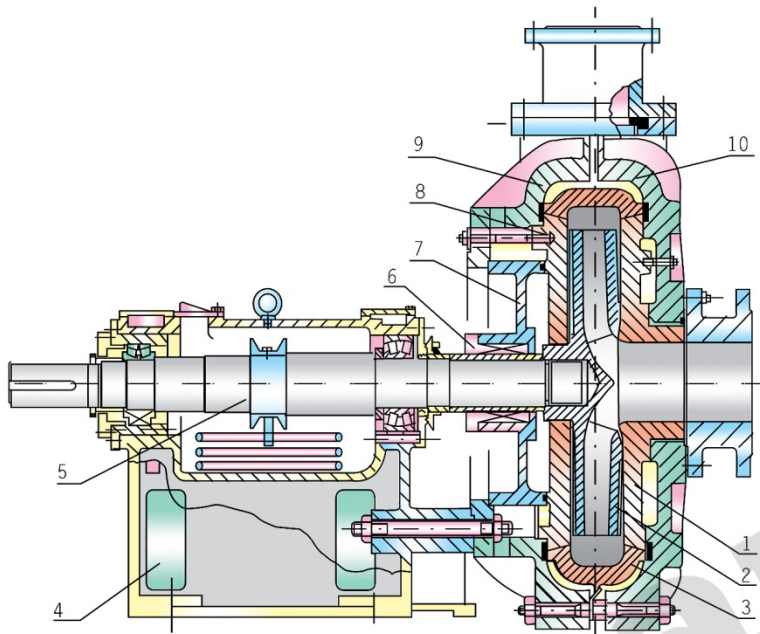

- | | |
|---------|----------------------|
| 1 前护板 | Throat bushing |
| 2 叶轮 | Impeller |
| 3 护套 | Volute liner |
| 4 托架体 | Support |
| 5 轴 | Shaft |
| 6 调整螺母乙 | Adjusting nut B |
| 7 调整螺母甲 | Adjusting nut A |
| 8 调整孔盖 | Adjusting hole cover |
| 9 减压盖 | Expeller ring |
| 10 副叶轮 | Expeller |
| 11 后护板 | Rear liner |
| 12 泵体 | Frame plate |
| 13 泵盖 | Cover plate |

2. ZGBP 型渣浆泵 Series ZGBP slurry pump

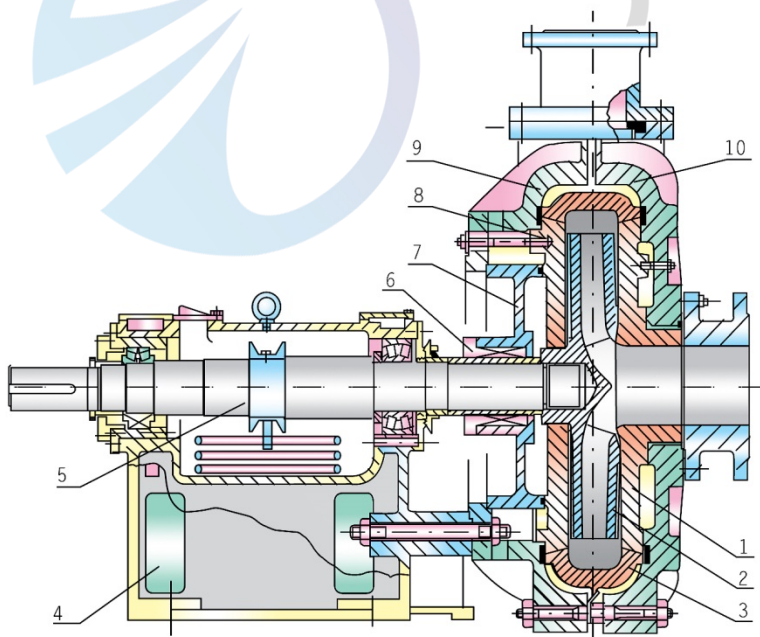

- | | |
|--------|-----------------|
| 1 前护板 | Throat bushing |
| 2 叶轮 | Impeller |
| 3 护套 | Volute liner |
| 4 托架体 | Support |
| 5 轴 | Shaft |
| 6 机械密封 | Mechanical seal |
| 7 密封箱 | Seal box |
| 8 后护板 | Rear liner |
| 9 泵体 | Frame plate |
| 10 泵盖 | Cover plate |

- 型谱 Selection Chart

ZGB(P) 型渣浆泵型谱
Type ZGB(P) Slurry Pump Selection Chart

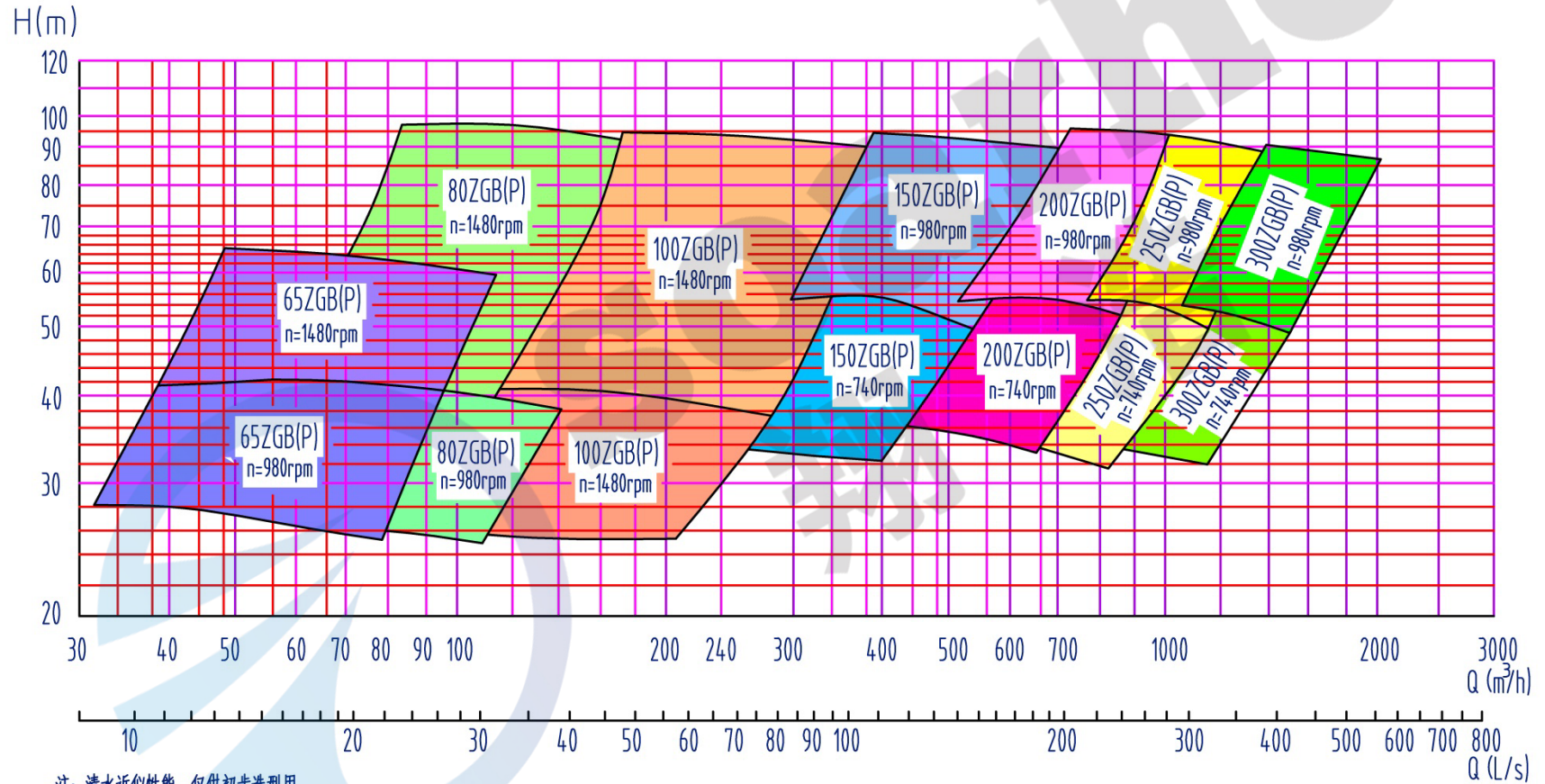

注：清水近似性能，仅供初步选型用。

NOTE: Apprximate performance for clear water, to be used for primary selection only.

• 性能参数表 Performance List

型号 Type	清水性能						轴功率 Power on shaft (KW)	电机功率 Power on motor (KW)	叶轮直径 Impeller Dia. (mm)	吐出口直径 /吸入口直径 Discharge Dia. /Suction Dia. (mm)	泵重 Pump weight (kg)
	转速 Speed (r/min)	流量 Capacity		扬程 Head (m)	效率 Eff. (%)	汽蚀余量 NPSHr (m)					
		(l/s)	(m3/h)								
65ZGB	1480	31.7	114.1	58	62.5	4.5	28.8	55	390	65/80	1850
		26.4	95.0	60	59.8	3.7	25.9	45			
		15.8	56.9	61	47.4	3.0	19.9	30			
	980	21.0	75.6	25.4	62.5	2.0	8.37	15			
		17.5	63.0	26.3	59.8	1.8	7.5	15			
		10.5	37.8	26.7	47.4	1.3	5.8	11			
80ZGB(P)	1480	56.7	204.1	87.5	66.1	5.2	73.7	132	485	80/100	2500
		47.2	169.9	90.0	63	4.1	66.1	110			
		28.3	101.9	91.6	48.7	2.7	52.2	90			
	980	37.5	135.0	37.4	66.1	2.3	21.4	37			
		31.3	112.7	39.5	63	1.8	19.2	30			
		18.8	67.7	40.2	48.7	1.2	15.2	30			
	1480	52.0	187.2	73.7	66.1	4.4	56.8	90	445		
		43.3	155.9	75.8	63	3.5	51.1	75			
		26.0	93.6	77.1	48.7	2.3	40.4	75			
	980	34.4	123.8	32.3	66.1	1.9	16.5	30			
		28.7	103.3	33.2	63	1.5	14.8	22			
		17.2	61.9	33.8	48.7	1.0	11.7	18.5			
	1480	46.8	168.5	59.5	66.1	3.5	41.3	75	400		
		38.9	140.0	61.2	63	2.8	37.0	55			
		23.3	83.9	62.3	48.7	1.8	29.2	55			
	980	31.0	111.6	26.1	66.1	1.5	12.0	18.5			
		25.8	92.9	26.8	63	1.2	10.8	18.5			
		15.4	55.4	27.3	48.7	0.8	8.4	15			

型号 Type	清水性能						轴功率 Power on shaft (KW)	电机功率 Power on motor (KW)	叶轮直径 Impeller Dia. (mm)	吐出口直径 /吸入口直径 Discharge Dia. /Suction Dia. (mm)	泵重 Pump weight (kg)	
	转速 Speed (r/min)	流量 Capacity		扬程 Head (m)	效率 Eff. (%)	汽蚀余量 NPSHr (m)						
		(l/s)	(m3/h)									
100ZGB(P)	1480	116.7	420.1	85.1	77.9	6.0	124.9	200	500	100/152	3000	
		97.2	349.9	88.2	74.4	3.8	113.0	185				
		58.3	209.9	91.8	57.4	2.6	91.4	160				
	980	77.3	278.3	37.3	77.9	2.7	36.3	55				
		64.4	231.8	38.7	74.4	1.7	32.8	55				
		38.6	139.0	40.3	57.4	1.2	26.6	45				
	1480	105	378.0	68.9	77.9	4.9	91.0	160	450			
		87.5	315.0	71.4	74.4	3.1	82.3	132				
		52.5	189.0	74.4	57.4	2.1	66.7	110				
	980	69.5	250.2	30.2	77.9	2.1	26.4	45				
		57.9	208.4	31.3	74.4	1.7	23.9	37				
		34.8	125.3	32.6	57.4	1.1	19.4	30				
	1480	93.4	336.2	54.5	77.9	3.8	64.0	110	400			
		77.8	280.1	56.4	74.4	2.4	57.8	90				
		46.7	168.1	58.8	57.4	1.7	46.9	75				
		980	61.8	222.5	23.9	77.9	1.7	18.6				30
			51.5	185.4	24.7	74.4	1.1	16.8				30
			30.9	111.2	25.8	57.4	0.8	13.6				22
150ZGB(P)	980	200.0	720.0	85.2	77.7	3.8	215.0	355	740	150/200	3450	
		167.0	601.2	87.5	70.0	3.5	204.7	315				
		100.0	360.0	90.0	53.3	2.7	165.5	280				
	740	151.2	544.3	48.6	77.7	2.2	92.7	160				
		126.0	453.6	49.9	70.0	2.0	88.1	160				
		75.6	272.2	51.3	53.3	1.5	71.3	132				

型号 Type	清水性能						轴功率 Power on shaft (KW)	电机功率 Power on motor (KW)	叶轮直径 Impeller Dia. (mm)	吐出口直径 /吸入口直径 Discharge Dia. /Suction Dia. (mm)	泵重 Pump weight (kg)
	转速 Speed (r/min)	流量 Capacity		扬程 Head (m)	效率 Eff. (%)	汽蚀余量 NPSHr (m)					
		(l/s)	(m3/h)								
150ZGB(P)	980	182.4	656.6	73.0	77.7	3.3	168.0	280	685		
		152.0	547.2	75.0	70.0	3.0	159.7	250			
		91.2	328.3	77.1	53.3	2.3	129.3	220			
	740	140.0	504.0	41.6	77.7	1.9	74.2	132			
		117.0	421.2	42.8	70.0	1.7	70.1	110			
		70.2	252.7	44.0	53.3	1.3	56.8	90			
	980	169.2	609.1	61.8	77.7	2.8	131.9	220	630		
		141.0	507.6	63.4	70.0	1.5	125.2	200			
		84.6	304.6	65.2	53.3	1.1	101.5	160			
	740	129.6	466.6	35.2	77.7	1.6	57.6	90			
		108.0	388.8	36.1	70.0	0.9	54.6	90			
		64.8	233.3	37.2	53.3	0.6	44.3	75			
200ZGB(P)	980	300.0	1080.0	89.0	76.3	6.7	342.9	560	740	200/250	4000
		250.0	900.0	93.4	73.7	5.6	310.5	560			
		150.0	540.0	94.2	63.2	2.7	219.1	355			
	740	226.5	815.4	50.7	76.3	3.8	147.5	220			
		188.5	678.6	53.3	73.7	3.2	134.3	200			
		113.3	407.9	53.7	63.2	1.5	94.3	160			
	980	283.8	1021.7	79.6	76.3	6.0	290.2	450	700		
		236.5	851.4	83.4	73.7	5.0	262.3	400			
		141.9	510.8	84.3	63.2	2.4	185.8	280			
	740	214.3	771.5	45.4	76.3	3.4	125.0	200			
		178.6	643.0	47.6	73.7	2.9	113.0	185			
		107.1	385.6	48.1	63.2	1.4	80.0	132			

型号 Type	清水性能					轴功率 Power on shaft (KW)	电机功率 Power on motor (KW)	叶轮直径 Impeller Dia. (mm)	吐出口直径 /吸入口直径 Discharge Dia. /Suction Dia. (mm)	泵重 Pump weight (kg)	
	转速 Speed (r/min)	流量 Capacity		扬程 Head (m)	效率 Eff. (%)						汽蚀余量 NPSHr (m)
200ZGB(P)	980	259.5	934.2	66.6	76.3	5.0	222.0	640			
		216.2	778.3	69.9	73.7	4.2	210.0				
		129.7	466.9	70.5	63.2	2.0	141.8				
	740	195.9	705.2	38.0	76.3	2.9	95.6				160
		134.9	485.6	39.9	73.7	2.4	71.6				110
		97.9	352.4	40.2	63.2	1.1	61.0				110
250ZGB(P)	980	400.0	1440.0	84.0	78.2	7.3	421.2	740			
		333.3	1199.9	88.0	77.0	5.7	373.4				560
		200.0	720.0	90.1	64.1	3.3	275.6				450
	740	302.0	1087.2	47.9	78.2	4.2	181.4				280
		251.7	906.1	50.2	77.0	3.3	160.9				250
		151.0	543.6	51.4	64.1	1.9	118.7				185
	980	378.4	1362.2	75.2	78.2	7.1	356.7	700	250/300	4500	
		315.3	1135.1	78.7	77.0	5.1	315.9				500
		189.2	681.1	80.6	64.1	3.0	233.2				355
	740	285.7	1028.5	42.9	78.2	4.0	153.7				250
		238.1	857.2	44.9	77.0	2.9	136.1				220
		142.9	514.4	46.0	64.1	1.7	100.5				160
	980	348.6	1255.0	63.8	78.2	5.5	278.8	645			
		290.5	1045.8	66.9	77.0	4.3	247.4				400
		131.6	473.8	68.5	64.1	2.5	137.9				220
	740	263.2	947.5	36.4	78.2	3.1	120.1				185
		219.4	789.8	38.1	77.0	2.5	106.4				185
		99.4	357.8	39.1	64.1	1.4	59.4				110

型号 Type	清水性能					轴功率 Power on shaft (KW)	电机功率 Power on motor (KW)	叶轮直径 Impeller Dia. (mm)	吐出口直径 /吸入口直径 Discharge Dia. /Suction Dia. (mm)	泵重 Pump weight (kg)						
	转速 Speed (r/min)	流量 Capacity		扬程 Head (m)	效率 Eff. (%)						汽蚀余量 NPSHr (m)					
300ZGB(P)	980	533.3	1919.9	84.3	81.2	6.9	542.8	760	300/350	5500						
		444.4	1599.8	89.8	80.0	5.0	489.1				710					
		266.7	960.1	93.4	68.3	3.5	357.6				560					
	740	402.7	1449.7	48.1	81.2	3.9	233.9				400					
		335.6	1208.2	51.2	80.0	2.9	210.6				315					
		201.3	724.7	53.3	68.3	2.0	154.0				250					
	980	493.3	1775.9	72.1	81.2	5.9	429.4	703			300/350	5500				
		411.1	1480.0	76.8	80.0	4.3	386.9						630			
		246.7	888.1	79.9	68.3	3.0	282.9						450			
	740	372.5	1341.0	41.4	81.2	3.4	184.8						315			
		310.4	1117.4	43.8	80.0	2.5	166.6						280			
		177.9	640.4	45.6	68.3	1.7	116.4						185			
	980	453.3	1631.9	60.9	81.2	5.0	333.3						646	300/350	5500	
		377.8	1360.1	64.6	80.0	3.6	300.5									500
		226.7	816.1	67.5	68.3	2.5	219.7									355
740	342.3	1232.3	34.7	81.2	2.9	143.4	250									
	285.3	1027.1	37.0	80.0	2.1	129.4	200									
	171.2	616.3	38.5	68.3	1.4	94.6	160									

• 外形尺寸图 Outline Drawing

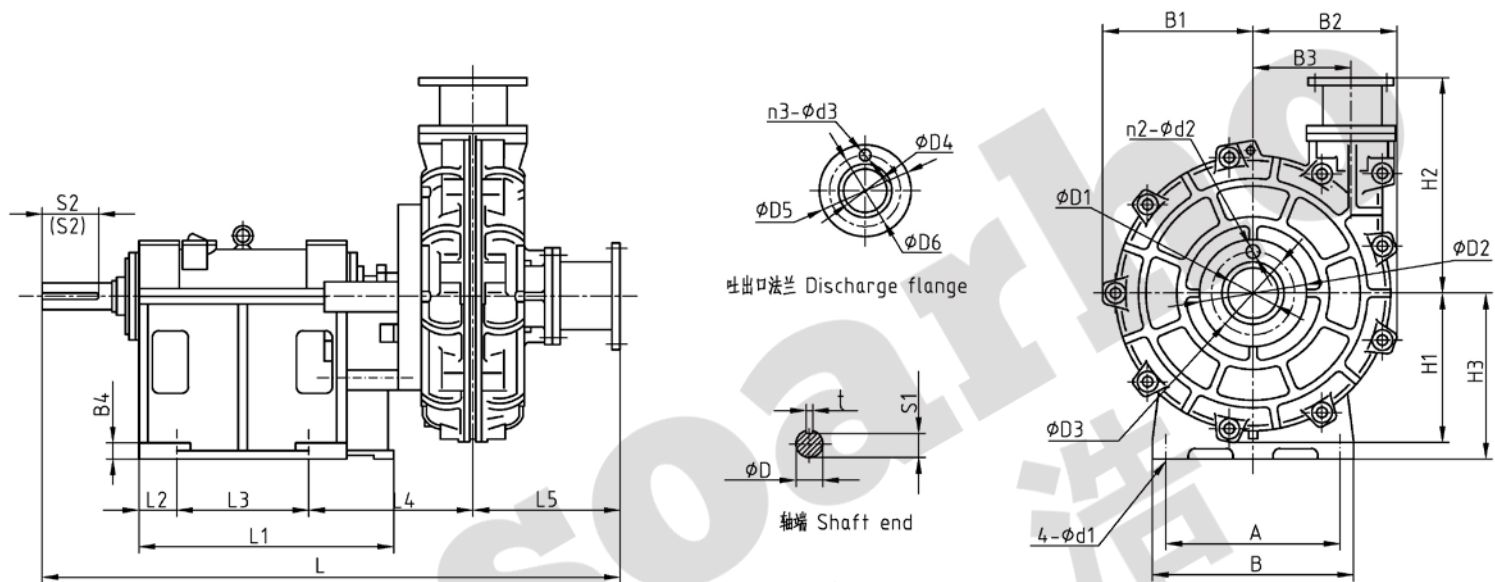

型号	A	B	B1	B2	B3	B4	D	D1	D2	D3	D4	D5	D6	H1	H2	H3	L	L1	L2	L3	L4	L5	d1	n2	d2	n3	d3	S1	S2	(S2)	t
65ZGB	432	492	352.5	377	220	45	65 ^{+0.01} _{+0.03}	80	210	168.5	65	190	149	360.5	475	415	1380	580	45	340	400.5	330	22	8	22	8	22	58 ⁰ _{-0.2}	150	--	18 ⁰ _{-0.043}
80ZGB(P)	560	636	360	445	279	50	80 ^{+0.01} _{+0.03}	100	255	200	80	210	168.5	383	560	520	1598	725	72	440	451	296	29	8	22	8	22	71 ⁰ _{-0.2}	203	180	22 ⁰ _{-0.052}
100ZGB(P)	560	636	395	467	290	50	80 ^{+0.01} _{+0.03}	152	320	270	100	275	216	394	597	520	1718	725	72	440	467	402	29	12	22	8	26	71 ⁰ _{-0.2}	203	180	22 ⁰ _{-0.052}
150ZGB(P)	760	840	619	684	453	60	120 ^{+0.01} _{+0.03}	200	380	330	150	320	270	655	820	650	2006	1013	118	560	615	388	35	12	26	12	22	109 ⁰ _{-0.2}	200	180	32 ⁰ _{-0.052}
200ZGB(P)	760	840	675	735	460	60	120 ^{+0.01} _{+0.03}	250	425	370	200	380	330	695	880	650	2213	1013	118	560	628	579	35	12	26	12	26	109 ⁰ _{-0.2}	200	180	32 ⁰ _{-0.052}
250ZGB(P)	780	950	645	710	460	60	120	300	515	450	250	445	387.5	680.3	974	650	2160	978	128	550	628	500	40	16	33	16	30	109 ⁰ _{-0.2}	200	180	32 ⁰ _{-0.052}
300ZGB	780	950	649	766	475	60	120	350	585	514.5	300	520	451	676	883	650	2282	978	128	550	668	610	40	20	33	16	33	109 ⁰ _{-0.2}	200	--	32 ⁰ _{-0.052}

注:1、S2 尺寸对应 ZGB, (S2)尺寸对应 ZGBP; 2、所有长度尺寸为 mm。

NOTE:1Size S2 corresponds to type ZGB and size (S2) corresponds to type ZGBP; 2.All length dimensions are mm.