



- 2.2W
- 260LM
- 10°*40°
- IP65
- LifeSpan 50,000h



Features >

- Sourced by high output LG LED, good color conformity and no spot.
- 99.99% gold thread, pure copper bracket coated with silver.
- SDCM≤5 each BIN.
- Special lens design, 10*40°beaming angle with even light.
- Overmoulded: anti-dusting, anti-moisture, waterproof, anti-shock.
- 20 pcs Max. in a series connection.
- CE, ROHS and UL certified.

Application >

- Best for 12-18 cm depth double-sided light box at airports, metros, banks, buildings and shopping malls, etc.

Parameters >

Items	Parameters
Part Number	ZX01QB2
CCT (K)	7000K
Beaming Angle (°)	10*40°
CRI (Ra)	≥75
Luminous Flux (lm)	260
Voltage (V)	DC12-24V
Power (W)	2.2
Driving Method	Inner Constant Current
Dimension (mm)	68*30*15
Weight (g)	9.57
Working Tem. (°C)	-25 ~ +60
Storage Tem. (°C)	-25 ~ +70
Protection Grade	IP65

Dimension >

Unit:mm

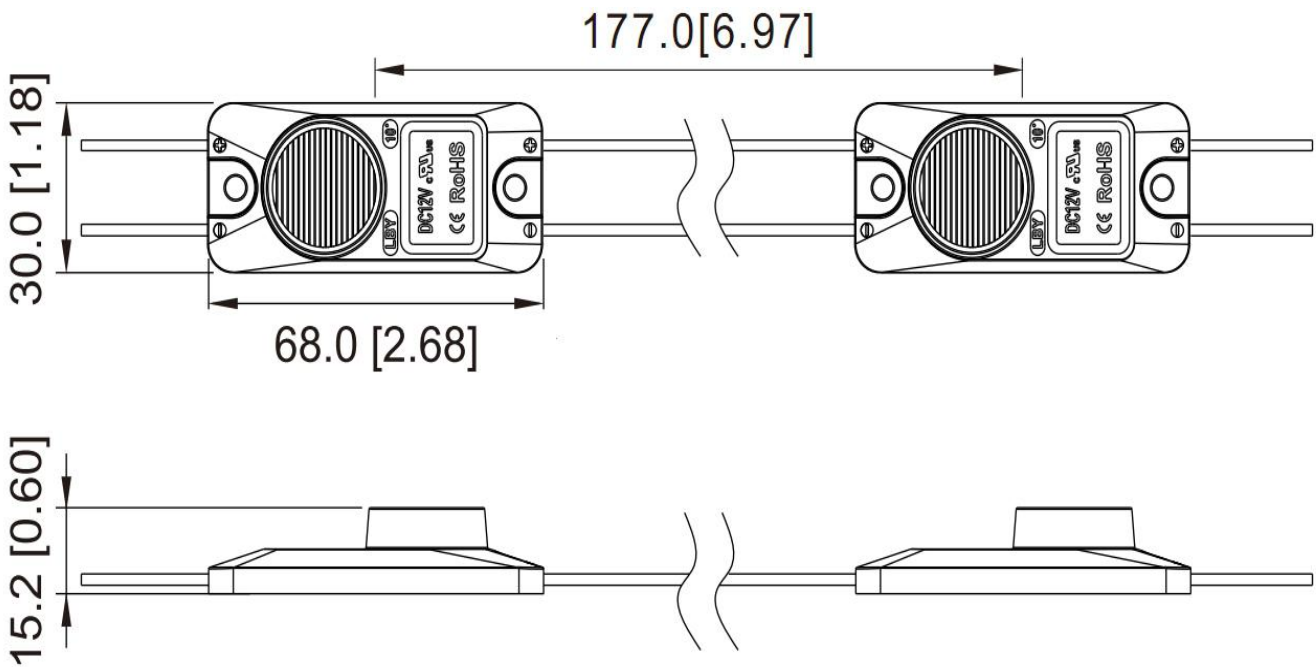

Beaming Angle >

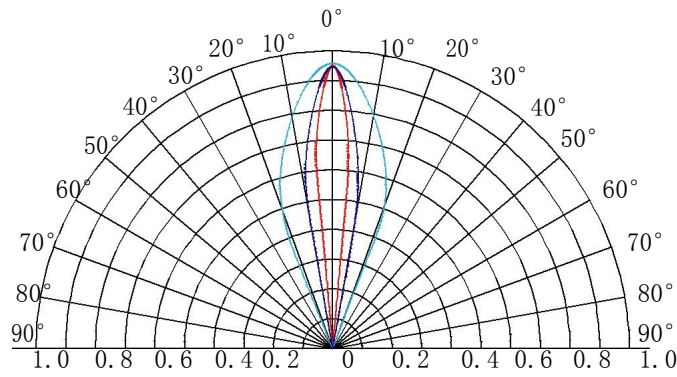

Reference Scheme >

Depth(mm)	Size(mm)	Density(pcs/m ²)	Illumination(lux)
120	1000*1000	24	1300-1500
150	1000*1000	24	1200-1300
200	1000*1000	24	1000-1200
300	1000*1000	24	800-900

Remark:

- The transmittance of the advertising fabric was 32%.
- The above data is for reference only.

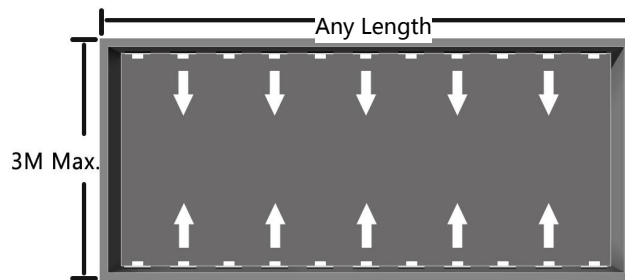

Wire Connection >

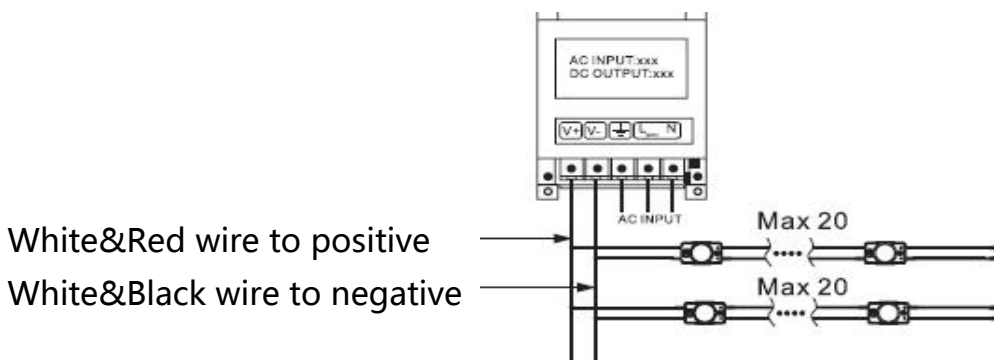

Packing



20pcs in a blister packing

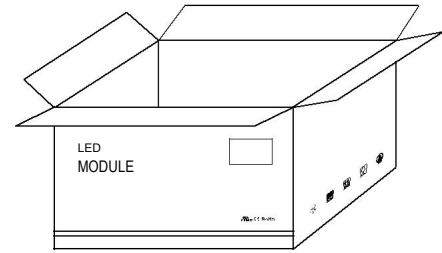

100 pcs in a carton

Packing Specification

- Packed in plastic tray.
- Packing information

Part Number	ZX01QB2
Carton dimension(mm)	355*255*180
Quantity per layer	20
Quantity per carton(pcs)	100
Net Weight(kg)	3.06 (±10%)
Gross Weight(kg)	4.25 (±10%)

- Due to the packing manner difference, please subject to the original products in case of discrepancy found between the picture and actual product.

Instruction

- When installing the product, please switch off the power.
- Please use constant voltage power supply and leave 20% or more balance of its total power.
- Make isolation and corrosion prevention on all wiring points and wire ends.
- The maximum series connection quantity for ZX01QB1/ZX01QB2/ZX01QB3 is 20 pcs , please do not exceed this number1.
- The products can be installed by screws, rivets as well as silicon gel, while please do not use Acidic or alkaline adhesive.
- For single side light box, in order to get better and even lighting effect, you can put the products more closer to unilluminated back and attach white reflective poly sheet or sheet with similar function on the inner back.

Declaration >

- Warranty: 5 years.
- In order to ensure the safety, the broken wires needs to be replaced by the manufacturer or the service agent, or by the staff with the similar qualification.
- The given data in the specification was based on the laboratory testing, there may be discrepancy found in the actual products.
- The given drawings in the specification are only for reference, there may be discrepancy found in the actual products.
- The products are subject to change without prior notification.



RoHS

Company Address:

Rm. WS, 9F, LuBan Building, Hongli West Road, Futian District, Shenzhen, China 518034

Factory Address:

No. B, Xinyongfeng Industrial Area, Yingrenshi Village, Shiyuan Town, Bao'an District, Shenzhen, China 518000

TEL: +86-755-83544570

FAX: +86-755-83056229

Website: www.lbyled.com

E-mail: info@szlby.cn



LBY LED
signs never been so easy