

JINAN KEYA ELECTRON SCIENCE AND TECHNOLOGY CO., LTD

***SCR* SERIES DC MOTOR DRIVE DISCRIPTIONS**

MMT- 110/220DR15/20/35AL



Summary

MMT-220DR serial DC motor drive adopts SCR chopper, which has unique trigger mode, thus making it more accurate and reliable. The drive is the update speed regulation product which develops and produces in combination with the international standard requirements and absorbs advanced technology experience. The drive has high performance-cost ratio because of its excellent performance and reliable quality. (It can reach high speed ratio even when at non-speed feedback) It is above average in DC motor drive field. Currently, the serial products have been exported to many countries and widely used in fields of domestic plastics machinery, food machinery, cable equipment, mechanical processing, papermaking, printing, experimental equipment, laboratory equipment, mixing equipment and so on.

Product Features

1. SMT technology Small volume
2. Applicable to permanent-magnet, separate excitation DC motor and DC torque motor
3. Dual closed loop PI adjustment (Current and Voltage)
4. Current setting and current limiting protection
5. The speed control mode and expansive force control mode are selectable.
6. Large torque for low-speed start-up.
7. Quick stop function
8. Upper limit and Low limit can be set up to different need
9. ACCEL and DECEL function
10. Standard signal interface0 — 5V or 10K potentiometer
11. Can realize remote start and stop, Fine following performance; immediate dynamic response
12. A wide speed-regulating range (0 - max).
13. Strong mechanical features, static voltage error 1%
14. A rapid dynamic response process. (adjustable)
15. Automatic and smooth transition process during acceleration or deceleration.
16. Good excavator features, can automatically overload current limit on the current settings.
17. High reliability, compact structure and highly cost-effective.

Main Parameters

1. AC Input Voltage : 110V 220V $\pm 10\%$ 。
2. AC Frequency (Hz):-50/60
3. Output voltage DC: 0~90V 0-110V 0-160V 0-180V 0-220V (Can be set)
3. Rated Armature current: (DC100V or 200V) 3-5A
4. Rated output current: 6A 8A 10A 20A 30A 35A
5. Speed adjust ratio: 1:100
6. Output voltage accuracy: $\leq 0.1\%$
7. Ambient temperature :-10°C- +60°C :
8. Ambient Humidity: Relative Humidity ≤ 80 RH. (Below dew point)
9. Ambient Humidity: Relative Humidity ≤ 80 RH. (Below dew point)
10. Insulation and voltage resistance: Input end with shell 1500V DC 1 minute
11. Insulation resistance: more than 20M Ω

- 12. Leak current: $\leq 0.9\text{mA}$
- 13. Size: 154*135*85mm
- 14. Weight: 1.25KG

Wiring requirements

1. Do not connect wire under charged circumstance.
2. Insulated connection, shielded wire which match with driver's voltage current shall be selected and connected, specifications of driver's power input wire and motor's wire are shown below:

Wire Specification and Length Table

Current (A)	Wire specification (mm ³)	Max. length (m)
15	2.5	15
20	4	15
35	6	15

3. Signal line and control line shall adopt shielded wire and shall be separated with power input wire and output wire.



WARNING

In any cases, signal line and logic control line shall not be bound, mixed and wired with power input wire, output wire (motor line) and other power lines. Induced voltage generated may cause interface, malfunction or directly damage the driver.

4. The driver do not have internal power supply and output reverse connection protection function, make sure that wiring between power input and driver is correct, otherwise the driver may be damaged.
5. Proper tools shall be used for wiring and make sure that wiring is correct.

Wiring schematic diagram

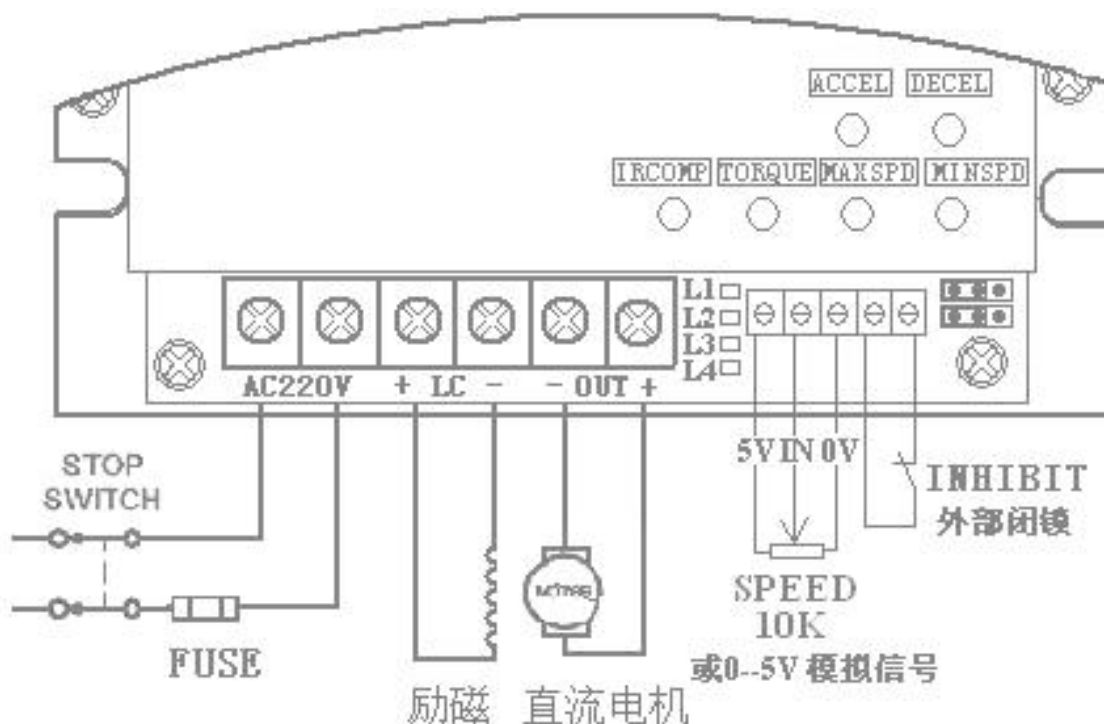

Enable control: INHIBIT

When both terminals of enable control terminals are closed, its internal circuit will rapidly promote motor rotating speed to the rated value.

When both terminals of enable control terminals are disconnected, its internal circuit will rapidly decrease motor rotating speed to make it stop. (Or decrease to the set value of MIN SPD).

Note: When control the start and stop of motor frequently, be sure to use this terminal control. Otherwise, damage to equipment may be caused.

Instructions on adjustment of potentiometer

1. The maximum rotation speed setting adjustment MAX SPD

A given potentiometer to adjust to the maximum, then adjust the MAX SPD potentiometer, limit the maximum output of motor speed.

2. Minimum speed limits: MIN SPD

A given potentiometer to adjust to a minimum, and then adjust the MIN SPD potentiometer, limit the minimum output of motor speed.

3. ACCEL Soft-start time adjustment: ACCEL (see figure 1)

This adjustment of potentiometers ACCEL can make sure motor's rising slope from the initial velocity up to the highest velocity (that is rising time, set time adjustable during 0-20 seconds).

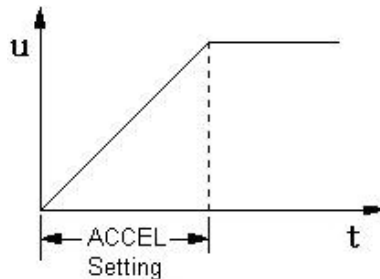

Figure 1

4. Soft-stop time adjustment (The interior has been fixed): DECEL

Adjustment of potentiometers DECEL can make sure motor's decline slope when speed dropped from the highest to the lowest (that is falling time, set time adjustable during 0-20 seconds). See Figure 2

Note: The actual speed will be the minimum MIN SPD potentiometer setting limits. Figure 2

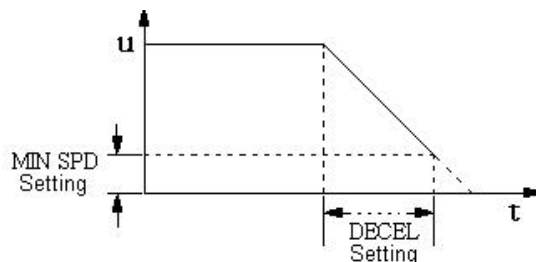

Figure 2

5. Current limit adjustment: TORQUE (when Under speed mode condition) Adjustment of the potentiometer can restrict drive plate to a maximum output current.

Based on your selection of the motor's rated current, we can use this potentiometer to adjust driver output current to match the motor rated current.

Note: In the choice of driver, the driver's maximum output current should be 120% to 200% of motor rated current.

6. Torque compensation adjustments: IR COMP (see figure W5)

Adjustment of the potentiometer can keep a constant rotation speed when motor works in different load.

Selection of speed mode and tension mode

1. Selection of speed mode:

When plugging in the CHI plug-in unit at A terminal (Two inserts should be converted to A terminal at the same time), it is the speed mode: see Figure 3.

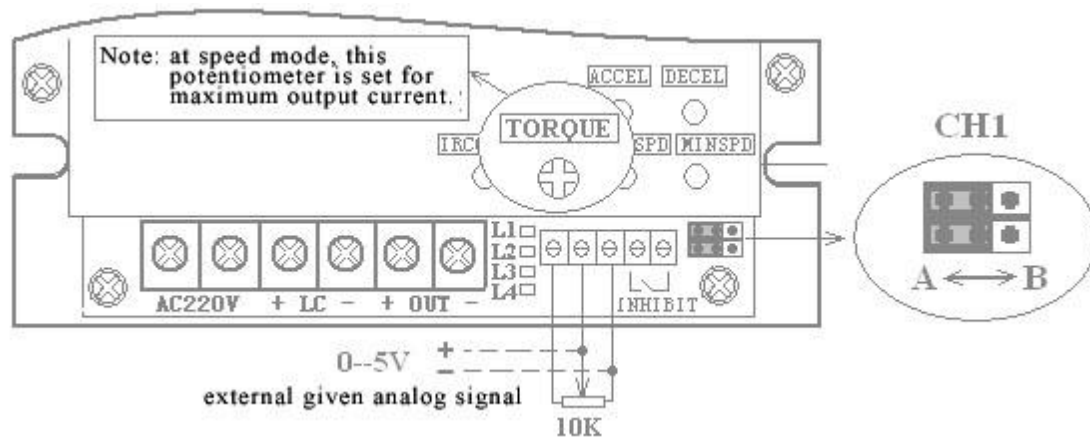

Figure 3

- a. When at speed mode, the external given signal (0-5V or potentiometer) acts on motor speed and the given signal is directly proportional to motor speed.
- b. When at speed mode, the adjusting potentiometer “TORQUE” above drive is used to adjust the maximum output current of drive.
- c. When the drive works steadily, please not select location of CHI. (Choose after power off)

2. Selection of tension mode

When plugging in the CHI plug-in unit at B terminal (Two inserts should be converted to B terminal at the same time), it is the tension mode: see Figure 4.

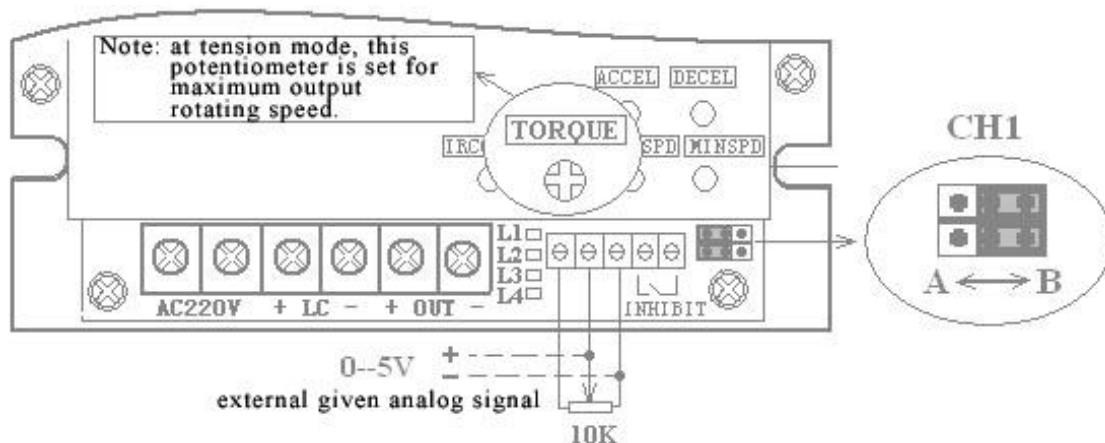

Figure 4

Note: a. when at tension mode, the given external signal (0-5V or potentiometer) acts on motor tension and the given signal is proportional to motor tension.

18. When at tension mode, the adjusting potentiometer above the drive “TORQUE” is used to adjust the maximum output voltage of it. (Namely the maximum speed of motor) .

19. When the drive works properly, please not select location of CHI. (Choose after power off)

Selection of input mode of control signal:

1. The serial products adopt the full isolation mode and the external given signal can connect directly with the signal input terminal of drive.

External potentiometers and analog signals for a given amount of signal for a given connection method: See Figure 5 and Figure 6

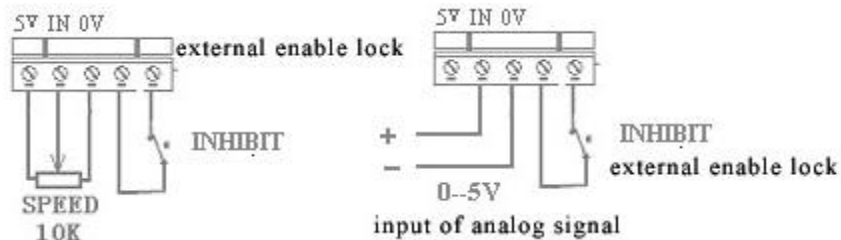

Figure 6

2. Several potentiometer series / parallel usage:

Means a potentiometer in parallel: This control mode enables two or more to adjust, use is simple and reliable. However, the total potentiometer resistance should be equal to 10K. (Potentiometer connection is best to use shielded line) shown in Figure 7

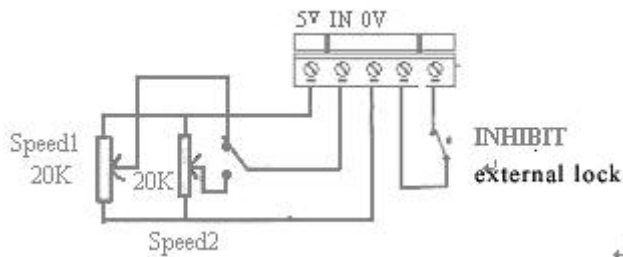

Figure 7

Mode 2: resistors in series connection:

This control method can achieve multi-stall speed control, used in a variety of occasions.

However, the total resistance of resistors in series shown in Figure 8 be equal to 10K/2W (see figure 8)

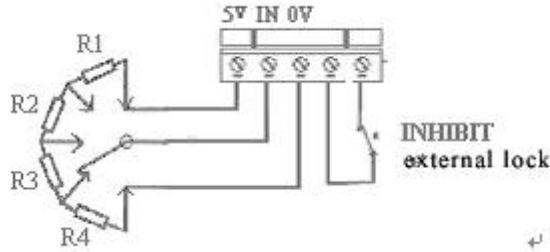

Figure 8

3. Rapid braking (dynamic braking) of the connection: Figure 9

Note: When using this method when braking (dynamic braking) Please be sure to enable the port used in conjunction with, otherwise it will damage the drive.

This control method can obtain good braking effect.

Braking resistor selection:

$$RW \text{ (braking resistor power) } = \text{motor actual power} \times (0.6-0.8)$$

$$R \text{ (braking resistor resistance) } = \text{Rated Voltage} / (\text{rated current} \times 1.2)$$

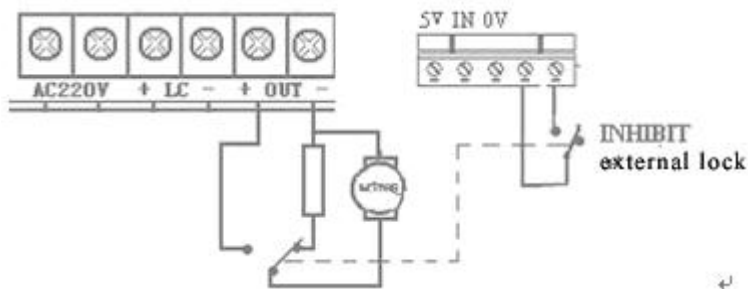

Figure 9

4. Forward / reverse change to control mode: Figure 10

Note: When using this method when braking (dynamic braking) Please be sure to enable the port used in conjunction with, otherwise it will damage the drive.

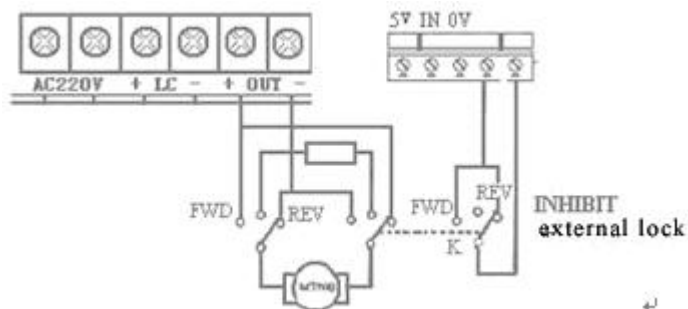
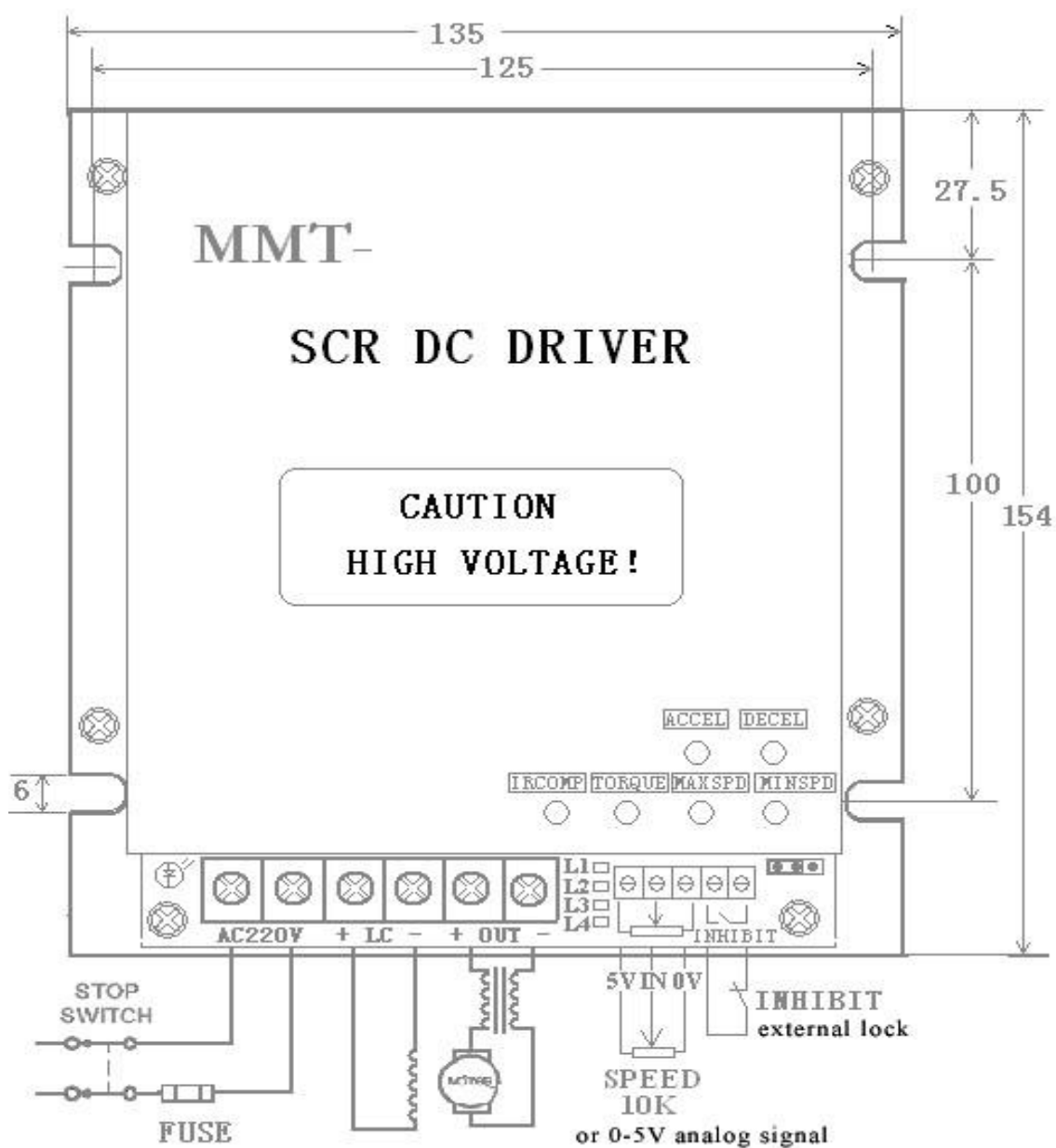

Figure 10

Instructions on the state of indicator lights

Indicator light	Bright state	Dark state
POWER (green) L1	Normal work power	without working power or drive is not normal
TORQUE (red) L2	Output current at the actual settings Or overload, short-circuit output	Current settings within the allowable range.
INHIBIT (Blue) L3	External enabling control block disconnect (stop work)	connect the external enabling control block (normal work)

Outline Drawing Size: 154*135*85mm



Caution: please make sure to examine the instruction book in detail before use.

JINAN KEYA ELECTRONIC CO., LTD

Website: [Http://www.jnkeya.com.cn](http://www.jnkeya.com.cn) [Http://www.jnky.com](http://www.jnky.com)

Tel: 86 0531--88973078

Fax: 86 0531-- 85898028

Email: sales@jnky.com